

## CrystalClear® Audio Codec '97 for Portable Computing

### Features

- Integrated Asynchronous I<sup>2</sup>S Input Port (ZV Port)
- Integrated High-Performance Microphone Pre-Amplifier
- Integrated Digital Effects Processing for Bass and Treble Response
- Digital Docking Including an I<sup>2</sup>S Output, 3 Synchronous I<sup>2</sup>S Inputs
- Performance Oriented Digital Mixer
- SRS® 3D Stereo Enhancement
- On-chip PLL for use with External Clock Sources
- Dedicated Microphone Analog-to-Digital Converter
- Sample Rate Converters
- S/PDIF Digital Audio Output
- AC '97 2.1 Compliant
- PC Beep Bypass
- 20-bit Stereo Digital-to-Analog Converters
- 18-bit Stereo Analog-to-Digital Converters

- Three Analog Line-level Stereo Inputs for LINE IN, VIDEO, and AUX
- High Quality Pseudo-Differential CD Input
- Extensive Power Management Support
- Meets or Exceeds the Microsoft® PC 99 and PC 2001 Audio Performance Requirements

### Description

The CS4205 is an AC '97 2.1 compliant stereo audio codec designed for PC multimedia systems. It uses industry leading CrystalClear® delta-sigma and mixed signal technology. The CS405 is the first Cirrus AC '97 audio codec to feature digital centric mixing and digital effects. This advanced technology and these features are designed to help enable the design of PC 99 and PC 2001 compliant high-quality audio systems for desktop, portable, and entertainment PCs.

Coupling the CS4205 with a PCI audio accelerator or core logic supporting the AC '97 interface implements a cost effective, superior quality audio solution. The CS4205 surpasses PC 99, PC 2001, and AC '97 2.1 audio quality standards.

### ORDERING INFO

CS4205-KQZ, Lead Free 48-pin TQFP 9x9x1.4 mm

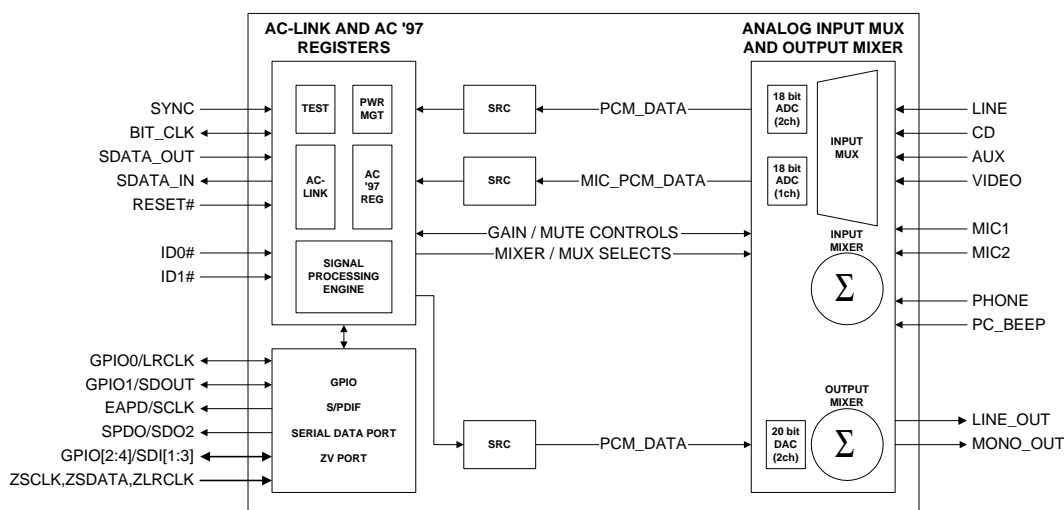

### Preliminary Product Information

This document contains information for a new product. Cirrus Logic reserves the right to modify this product without notice.

---

**TABLE OF CONTENTS**

<b>1. CHARACTERISTICS AND SPECIFICATIONS .....</b>	<b>6</b>
ANALOG CHARACTERISTICS .....	6
ABSOLUTE MAXIMUM RATINGS .....	7
RECOMMENDED OPERATING CONDITIONS .....	7
AC '97 SERIAL PORT TIMING .....	9
<b>2. GENERAL DESCRIPTION .....</b>	<b>12</b>
2.1 AC-Link .....	12
2.2 Control Registers .....	13
2.3 Sample Rate Converters .....	13
2.4 Mixers .....	13
2.5 Input Mux .....	13
2.6 Volume Control .....	13
2.7 Dedicated Mic Record Path .....	13
<b>3. DIGITAL SIGNAL PATHS .....</b>	<b>15</b>
3.1 Analog Centric Mode .....	15
3.2 Digital Centric Mode .....	16
3.3 Host Processing Mode .....	16
3.4 Multi-Channel Mode .....	16
<b>4. AC-LINK FRAME DEFINITION .....</b>	<b>18</b>
4.1 AC-Link Serial Data Output Frame .....	19
4.1.1 Serial Data Output Slot Tags (Slot 0).....	19
4.1.2 Command Address Port (Slot 1).....	19
4.1.3 Command Data Port (Slot 2).....	20
4.1.4 PCM Playback Data (Slots 3-11) .....	20
4.1.5 GPIO Pin Control (Slot12).....	20
4.2 AC-Link Serial Data Input Frame .....	21
4.2.1 Serial Data Input Slot Tag Bits (Slot 0) .....	21
4.2.2 Status Address Port (Slot 1) .....	21
4.2.3 Status Data Port (Slot 2).....	22
4.2.4 PCM Capture Data (Slot 3-8,11).....	22

---

**Contacting Cirrus Logic Support**

For a complete listing of Direct Sales, Distributor, and Sales Representative contacts, visit the Cirrus Logic web site at:  
<http://www.cirrus.com/corporate/contacts/sales.cfm>

---

**IMPORTANT NOTICE**

"Preliminary" product information describes products that are in production, but for which full characterization data is not yet available. Cirrus Logic, Inc. and its subsidiaries ("Cirrus") believe that the information contained in this document is accurate and reliable. However, the information is subject to change without notice and is provided "AS IS" without warranty of any kind (express or implied). Customers are advised to obtain the latest version of relevant information to verify, before placing orders, that information being relied on is current and complete. All products are sold subject to the terms and conditions of sale supplied at the time of order acknowledgment, including those pertaining to warranty, indemnification, and limitation of liability. No responsibility is assumed by Cirrus for the use of this information, including use of this information as the basis for manufacture or sale of any items, or for infringement of patents or other rights of third parties. This document is the property of Cirrus and by furnishing this information, Cirrus grants no license, express or implied under any patents, mask work rights, copyrights, trademarks, trade secrets or other intellectual property rights. Cirrus owns the copyrights associated with the information contained herein and gives consent for copies to be made of the information only for use within your organization with respect to Cirrus integrated circuits or other products of Cirrus. This consent does not extend to other copying such as copying for general distribution, advertising or promotional purposes, or for creating any work for resale.

CERTAIN APPLICATIONS USING SEMICONDUCTOR PRODUCTS MAY INVOLVE POTENTIAL RISKS OF DEATH, PERSONAL INJURY, OR SEVERE PROPERTY OR ENVIRONMENTAL DAMAGE ("CRITICAL APPLICATIONS"). CIRRUS PRODUCTS ARE NOT DESIGNED, AUTHORIZED OR WARRANTED FOR USE IN AIRCRAFT SYSTEMS, MILITARY APPLICATIONS, PRODUCTS SURGICALLY IMPLANTED INTO THE BODY, AUTOMOTIVE SAFETY OR SECURITY DEVICES, LIFE SUPPORT PRODUCTS OR OTHER CRITICAL APPLICATIONS. INCLUSION OF CIRRUS PRODUCTS IN SUCH APPLICATIONS IS UNDERSTOOD TO BE FULLY AT THE CUSTOMER'S RISK AND CIRRUS DISCLAIMS AND MAKES NO WARRANTY, EXPRESS, STATUTORY OR IMPLIED, INCLUDING THE IMPLIED WARRANTIES OF MERCHANTABILITY AND FITNESS FOR PARTICULAR PURPOSE, WITH REGARD TO ANY CIRRUS PRODUCT THAT IS USED IN SUCH A MANNER. IF THE CUSTOMER OR CUSTOMER'S CUSTOMER USES OR PERMITS THE USE OF CIRRUS PRODUCTS IN CRITICAL APPLICATIONS, CUSTOMER AGREES, BY SUCH USE, TO FULLY INDEMNIFY CIRRUS, ITS OFFICERS, DIRECTORS, EMPLOYEES, DISTRIBUTORS AND OTHER AGENTS FROM ANY AND ALL LIABILITY, INCLUDING ATTORNEYS' FEES AND COSTS, THAT MAY RESULT FROM OR ARISE IN CONNECTION WITH THESE USES.

Cirrus Logic, Cirrus, and the Cirrus Logic logo designs are trademarks of Cirrus Logic, Inc. All other brand and product names in this document may be trademarks or service marks of their respective owners.

4.2.5 GPIO Pin Status (Slot 12) .....	22
4.3 AC-Link Protocol Violation - Loss of SYNC .....	23
<b>5. REGISTER INTERFACE .....</b>	<b>24</b>
5.1 Reset Register (Index 00h) .....	26
5.2 Master Volume Register (Index 02h) .....	26
5.3 Mono Volume Register (Index 06h) .....	28
5.4 Master Tone Control Register (Index 08h) .....	28
5.5 PC_BEEP Volume Register (Index 0Ah) .....	29
5.6 Phone Volume Register (Index 0Ch) .....	29
5.7 Microphone Volume Register (Index 0Eh) .....	30
5.8 Analog Mixer Input Gain Registers (Index 10h - 18h) .....	31
5.9 Input Mux Select Register (Index 1Ah) .....	32
5.10 Record Gain Register (Index 1Ch) .....	33
5.11 Record Gain Mic Register (Index 1Eh) .....	33
5.12 General Purpose Register (Index 20h) .....	34
5.13 3D Control Register (Index 22h) .....	34
5.14 Powerdown Control/Status Register (Index 26h) .....	35
5.15 Extended Audio ID Register (Index 28h) .....	36
5.16 Extended Audio Status/Control Register (Index 2Ah) .....	37
5.17 Audio Sample Rate Control Registers (Index 2Ch - 34h) .....	38
5.18 Extended Modem ID Register (Index 3Ch) .....	39
5.19 Extended Modem Status/Control Register (Index 3Eh) .....	39
5.20 GPIO Pin Configuration Register (Index 4Ch) .....	39
5.21 GPIO Pin Polarity/Type Configuration Register (Index 4Eh) .....	40
5.22 GPIO Pin Sticky Register (Index 50h) .....	40
5.23 GPIO Pin Wakeup Mask Register (Index 52h) .....	41
5.24 GPIO Pin Status Register (Index 54h) .....	41
5.25 AC Mode Control Register (Index 5Eh) .....	41
5.26 Misc. Crystal Control Register (Index 60h) .....	44
5.27 S/PDIF Control Register (Index 68h) .....	45
5.28 Serial Port Control Register (Index 6Ah) .....	46
5.29 Special Feature Address Register (Index 6Ch) .....	47
5.30 Special Feature Data Register (Index 6Eh) .....	47
5.31 Digital Mixer Input Volume Registers (Index 6Eh, Address 00h - 05h) .....	47
5.32 Serial Data Port Volume Control Registers (Index 6Eh, Address 06h - 07h) .....	48
5.33 Signal Processing Engine Control Register (Index 6Eh, Address 08h) .....	49
5.34 Internal Error Condition Control/Status Registers (Index 6Eh, Address 09h - 0Bh) .....	50
5.35 BIOS-Driver Interface Control Registers (Index 6Eh, Address 0Ch - 0Dh) .....	51
5.36 ZV Port Control/Status Registers (Index 6Eh, Address 0Eh - 0Fh) .....	51
5.37 BIOS-Driver Interface Status Register (Index 7Ah) .....	51
5.38 Vendor ID1 Register (Index 7Ch) .....	53
5.39 Vendor ID2 Register (Index 7Eh) .....	53
<b>6. SERIAL DATA PORTS .....</b>	<b>54</b>
6.1 Overview .....	54
6.2 Multi-Channel Expansion .....	54
6.3 Digital Docking .....	55
6.4 Serial Data Formats .....	55
<b>7. ZV PORT .....</b>	<b>57</b>
<b>8. SONY/PHILIPS DIGITAL INTERFACE (S/PDIF) .....</b>	<b>58</b>
<b>9. EXCLUSIVE FUNCTIONS .....</b>	<b>58</b>
<b>10. POWER MANAGEMENT .....</b>	<b>59</b>
10.1 AC '97 Reset Modes .....	59
10.1.1 Cold Reset .....	59
10.1.2 Warm Reset .....	59

10.1.3 New Warm Reset .....	59
10.1.4 Register Reset .....	59
10.2 Powerdown Controls .....	60
<b>11. CLOCKING .....</b>	<b>62</b>
11.1 PLL Operation (External Clock) .....	62
11.2 24.576 MHz Crystal Operation .....	62
11.3 Secondary Codec Operation .....	62
<b>12. ANALOG HARDWARE DESCRIPTION .....</b>	<b>64</b>
12.1 Analog Inputs .....	64
12.1.1 Line Inputs .....	64
12.1.2 CD Input .....	64
12.1.3 Microphone Inputs .....	65
12.1.4 PC Beep Input .....	65
12.1.5 Phone Input .....	65
12.2 Analog Outputs .....	65
12.2.1 Stereo Output .....	66
12.2.2 Mono Output .....	66
12.3 Miscellaneous Analog Signals .....	66
12.4 Power Supplies .....	66
12.5 Reference Design .....	67
<b>13. GROUNDING AND LAYOUT .....</b>	<b>68</b>
<b>14. PIN DESCRIPTIONS .....</b>	<b>70</b>
<b>15. PARAMETER AND TERM DEFINITIONS .....</b>	<b>77</b>
<b>16. REFERENCE DESIGN .....</b>	<b>79</b>
<b>17. REFERENCES .....</b>	<b>80</b>
<b>18. PACKAGE DIMENSIONS .....</b>	<b>81</b>

## LIST OF FIGURES

Figure 1. Power Up Timing.....	10
Figure 2. Codec Ready from Start-up or Fault Condition .....	10
Figure 3. Clocks .....	10
Figure 4. Data Setup and Hold.....	11
Figure 5. PR4 Powerdown and Warm Reset .....	11
Figure 6. Test Mode .....	11
Figure 7. AC-link Connections.....	12
Figure 8. CS4205 Mixer Diagram.....	14
Figure 9. Digital Signal Path Overview.....	15
Figure 10. Analog Centric Mode.....	17
Figure 11. Digital Centric Mode.....	17
Figure 12. Host Processing Mode .....	17
Figure 13. Multi-Channel Mode .....	17
Figure 14. AC-link Input and Output Framing.....	18
Figure 15. Serial Data Port: Six Channel Circuit .....	54
Figure 16. Digital Docking Connection Diagram .....	55
Figure 17. Serial Data Format 0 (I2S) .....	56
Figure 18. Serial Data Format 1 (Left Justified) .....	56
Figure 19. Serial Data Format 2 (Right Justified, 20-bit data) .....	56
Figure 20. Serial Data Format 3 (Right Justified, 16-bit data) .....	56
Figure 21. ZV Port Format (I2S, 16-bit data).....	57
Figure 22. S/PDIF Output.....	58
Figure 23. PLL External Loop Filter.....	62
Figure 24. External Crystal.....	63

---

Figure 25. Line Input (Replicate for Video and AUX) .....	64
Figure 26. Differential 2 VRMS CD Input .....	64
Figure 27. Differential 1 VRMS CD Input .....	64
Figure 28. Microphone Input .....	65
Figure 29. PC_BEEP Input .....	65
Figure 30. Modem Connection.....	65
Figure 31. Stereo Output.....	66
Figure 32. +5V Analog Voltage Regulator .....	66
Figure 33. Conceptual Layout for the CS4205 when in XTAL or OSC Clocking Modes.....	69
Figure 34. Pin Locations for the CS4205 .....	70
Figure 35. CS4205 Reference Design .....	79

---

**LIST OF TABLES**

Table 1. AC Mode Control Configurations .....	16
Table 2. Register Overview for the CS4205 .....	24
Table 3. Indirectly Addressed Register Overview .....	25
Table 4. Analog Mixer Output Attenuation .....	26
Table 5. Tone Control Values .....	28
Table 6. Microphone Input Gain Values.....	30
Table 7. Analog Mixer Input Gain Values .....	31
Table 8. Analog Mixer Input Gain Register Index .....	31
Table 9. Input Mux Selection .....	32
Table 10. Record Gain Values.....	33
Table 11. Audio Sample Rate Control Register Index .....	38
Table 12. Directly Supported SRC Sample Rates for the CS4205 .....	38
Table 13. GPIO Input/Output Configurations .....	40
Table 14. Slot Mapping for the CS4205.....	43
Table 15. Digital Signal Source Selects.....	43
Table 16. Serial Data Format Selection .....	46
Table 17. Digital Mixer Input Volume Register Index.....	47
Table 18. Serial Port Volume Control Register Index .....	48
Table 19. Volume Change Modes and EQ Filter Selects .....	49
Table 20. Internal Error Sources and Correction Methods .....	50
Table 21. ZV Port Control/Status Register Index.....	51
Table 22. Device ID with Corresponding Part Number .....	53
Table 23. Serial Data Formats and Compatible DACs/ADC's for the CS4205 .....	56
Table 24. Powerdown PR Bit Functions .....	60
Table 25. Powerdown PR Function Matrix for the CS4205 .....	61
Table 26. Power Consumption by Powerdown Mode for the CS4205.....	61
Table 27. Clocking Configurations for the CS4205.....	63

## 1. CHARACTERISTICS AND SPECIFICATIONS

**ANALOG CHARACTERISTICS** (Standard test conditions unless otherwise noted:  $T_{\text{ambient}} = 25^{\circ}\text{C}$ ,  $AV_{\text{dd}} = 5.0\text{ V} \pm 5\%$ ,  $DV_{\text{dd}} = 3.3\text{ V} \pm 5\%$ ; 1 kHz Input Sine wave; Sample Frequency,  $F_s = 48\text{ kHz}$ ;  $Z_{\text{AL}} = 100\text{ k}\Omega$ /1000 pF load for Mono and Line Outputs;  $C_{\text{DL}} = 18\text{ pF}$  load (Note 1); Measurement bandwidth is 20 Hz - 20 kHz, 18-bit linear coding for ADC functions, 20-bit linear coding for DAC functions; Mixer registers set for unity gain.

Parameter (Note 2)	Symbol	Path (Note 3)	CS4205-KQZ			Unit
			Min	Typ	Max	
Full Scale Input Voltage						
Line Inputs		A-D	0.91	1.00	-	$V_{\text{RMS}}$
Mic Inputs (10dB = 0, 20dB = 0)		A-D	0.91	1.00	-	$V_{\text{RMS}}$
Mic Inputs (10dB = 1, 20dB = 0)		A-D	0.283	0.315	-	$V_{\text{RMS}}$
Mic Inputs (10dB = 0, 20dB = 1)		A-D	0.091	0.10	-	$V_{\text{RMS}}$
Mic Inputs (10dB = 1, 20dB = 1)		A-D	0.0283	0.0315	-	$V_{\text{RMS}}$
Full Scale Output Voltage						
Line and Mono Outputs		D-A	0.91	1.0	1.13	$V_{\text{RMS}}$
Frequency Response (Note 4)	FR					
Analog $A_c = \pm 0.25\text{ dB}$		A-A	20	-	20,000	Hz
DAC $A_c = \pm 0.25\text{ dB}$		D-A	20	-	20,000	Hz
ADC $A_c = \pm 0.25\text{ dB}$		A-D	20	-	20,000	Hz
Dynamic Range	DR					
Stereo Analog Inputs to LINE_OUT		A-A	90	95	-	dB FS A
Mono Analog Input to LINE_OUT		A-A	85	90	-	dB FS A
DAC Dynamic Range		D-A	85	90	-	dB FS A
ADC Dynamic Range		A-D	85	90	-	dB FS A
DAC SNR (-20 dB FS input w/ CCIR-RMS filter on output)	SNR	D-A	-	70	-	dB
Total Harmonic Distortion + Noise (-3 dB FS input signal):	THD+N					
Line Output		A-A	-	-90	-80	dB FS
DAC		D-A	-	-87	-80	dB FS
ADC (all inputs)		A-D	-	-84	-80	dB FS
Power Supply Rejection Ratio (1 kHz, $0.5 V_{\text{RMS}}$ w/ 5 V DC offset) (Note 4)			40	60	-	dB
Interchannel Isolation			70	87	-	dB
Spurious Tone (Note 4)			-	-100	-	dB FS
Input Impedance (Note 4)			10	-	-	$\text{k}\Omega$

- Notes:
1.  $Z_{\text{AL}}$  refers to the analog output pin loading and  $C_{\text{DL}}$  refers to the digital output pin loading.
  2. Parameter definitions are given in Section 15, *Parameter and Term Definitions*.
  3. Path refers to the signal path used to generate this data. These paths are defined in Section 15, *Parameter and Term Definitions*.
  4. This specification is guaranteed by silicon characterization; it is not production tested.

**ANALOG CHARACTERISTICS** (Continued)

Parameter (Note 2)	Symbol	Path (Note 3)	CS4205-KQZ			Unit
			Min	Typ	Max	
External Load Impedance Line Output, Mono Output			10	-	-	k $\Omega$
Output Impedance Line Output, Mono Output (Note 4)			-	730	-	$\Omega$
Input Capacitance (Note 4)			-	5	-	pF
Vrefout			2.3	2.4	2.5	V

**MIXER CHARACTERISTICS**

Parameter	Min	Typ	Max	Unit
Mixer Gain Range Span				
PC Beep	-	45.0	-	dB
Line In, Aux, CD, Video, Mic1, Mic2, Phone	-	46.5	-	dB
Mono Out, Line Out	-	46.5	-	dB
ADC Gain	-	22.5	-	dB
Step Size				
All volume controls except PC Beep	-	1.5	-	dB
PC Beep	-	3.0	-	dB

**ABSOLUTE MAXIMUM RATINGS** (AVss1 = AVss2 = DVss1 = DVss2 = 0 V)

Parameter	Min	Typ	Max	Unit
Power Supplies				
+3.3 V Digital	-0.3	-	5.5	V
+5 V Digital	-0.3	-	5.5	V
Analog	-0.3	-	5.5	V
Total Power Dissipation (Supplies, Inputs, Outputs)	-	-	1.25	W
Input Current per Pin (Except Supply Pins)	-10	-	10	mA
Output Current per Pin (Except Supply Pins)	-15	-	15	mA
Analog Input voltage	-0.3	-	AVdd+ 0.3	V
Digital Input voltage	-0.3	-	DVdd + 0.3	V
Ambient Temperature (Power Applied)	0	-	70	$^{\circ}$ C
Storage Temperature	-65	-	150	$^{\circ}$ C

**RECOMMENDED OPERATING CONDITIONS** (AVss1 = AVss2 = DVss1 = DVss2 = 0 V)

Parameter	Symbol	Min	Typ	Max	Unit
Power Supplies					
+3.3 V Digital	DVdd1, DVdd2	3.135	3.3	3.465	V
+5 V Digital	DVdd1, DVdd2	4.75	5	5.25	V
Analog	AVdd1, AVdd2	4.75	5	5.25	V
Operating Ambient Temperature		0	-	70	$^{\circ}$ C



**DIGITAL CHARACTERISTICS** (AVss1 = AVss2 = DVss1 = DVss2 = 0 V)

Parameter	Symbol	Min	Typ	Max	Unit
<b>DVdd = 3.3V</b>					
Low level input voltage	$V_{il}$	-	-	0.80	V
High level input voltage	$V_{ih}$	2.15	-	-	V
High level output voltage	$V_{oh}$	3.00	3.25	-	V
Low level output voltage	$V_{ol}$	-	0.03	0.35	V
Input Leakage Current (AC-link inputs)		-10	-	10	$\mu$ A
Output Leakage Current (Tri-stated AC-link outputs)		-10	-	10	$\mu$ A
Output buffer drive current BIT_CLK, SPDO/SDO2		-	24	-	mA
SDATA_IN, EAPD/SCLK, GPIO0/LRCLK, GPIO1/SDOUT, GPIO2/SDI1, GPIO3/SDI2, GPIO4/SDI3 (Note 4)		-	4	-	mA
<b>DVdd = 5.0 V</b>					
Low level input voltage	$V_{il}$	-	-	0.80	V
High level input voltage	$V_{ih}$	3.25	-	-	V
High level output voltage	$V_{oh}$	4.50	4.95	-	V
Low level output voltage	$V_{ol}$	-	0.03	0.35	V
Input Leakage Current (AC-link inputs)		-10	-	10	$\mu$ A
Output Leakage Current (Tri-stated AC-link outputs)		-10	-	10	$\mu$ A
Output buffer drive current BIT_CLK, SPDO/SDO2		-	24	-	mA
SDATA_IN, EAPD/SCLK, GPIO0/LRCLK, GPIO1/SDOUT, GPIO2/SDI1, GPIO3/SDI2, GPIO4/SDI3 (Note 4)		-	4	-	mA

**AC '97 SERIAL PORT TIMING** Standard test conditions unless otherwise noted:  $T_{\text{ambient}} = 25^{\circ}\text{C}$ ,  $AV_{\text{dd}} = 5.0\text{V}$ ,  $DV_{\text{dd}} = 3.3\text{V}$ ;  $C_L = 55\text{pF}$  load.

Parameter	Symbol	Min	Typ	Max	Unit
<b>RESET Timing</b>					
RESET# active low pulse width	$T_{\text{rst\_low}}$	1.0	-	-	$\mu\text{s}$
RESET# inactive to BIT_CLK start-up delay	(XTL mode)	-	4.0	-	$\mu\text{s}$
	(OSC mode)	-	4.0	-	$\mu\text{s}$
	(PLL mode)	-	2.5	-	ms
1st SYNC active to CODEC READY 'set'	$T_{\text{sync2crd}}$	-	62.5	-	$\mu\text{s}$
Vdd stable to RESET# inactive	$T_{\text{vdd2rst\#}}$	100	-	-	$\mu\text{s}$
<b>Clocks</b>					
BIT_CLK frequency	$F_{\text{clk}}$	-	12.288	-	MHz
BIT_CLK period	$T_{\text{clk\_period}}$	-	81.4	-	ns
BIT_CLK output jitter (depends on XTL_IN source)		-	-	750	ps
BIT_CLK high pulse width	$T_{\text{clk\_high}}$	36	40.7	45	ns
BIT_CLK low pulse width	$T_{\text{clk\_low}}$	36	40.7	45	ns
SYNC frequency	$F_{\text{sync}}$	-	48	-	kHz
SYNC period	$T_{\text{sync\_period}}$	-	20.8	-	$\mu\text{s}$
SYNC high pulse width	$T_{\text{sync\_high}}$	-	1.3	-	$\mu\text{s}$
SYNC low pulse width	$T_{\text{sync\_low}}$	-	19.5	-	$\mu\text{s}$
<b>Data Setup and Hold</b>					
Output propagation delay from rising edge of BIT_CLK	$T_{\text{co}}$	8	10	12	ns
Input setup time from falling edge of BIT_CLK	$T_{\text{isetup}}$	10	-	-	ns
Input hold time from falling edge of BIT_CLK	$T_{\text{ihold}}$	0	-	-	ns
Input signal rise time	$T_{\text{irise}}$	2	-	6	ns
Input signal fall time	$T_{\text{ifall}}$	2	-	6	ns
Output signal rise time (Note 4)	$T_{\text{orise}}$	2	4	6	ns
Output signal fall time (Note 4)	$T_{\text{ofall}}$	2	4	6	ns
<b>Misc. Timing Parameters</b>					
End of Slot 2 to BIT_CLK, SDATA_IN low (PR4)	$T_{\text{s2\_pdown}}$	-	0.2	1.0	$\mu\text{s}$
SYNC pulse width (PR4) Warm Reset	$T_{\text{sync\_pr4}}$	1.0	-	-	$\mu\text{s}$
SYNC inactive (PR4) to BIT_CLK start-up delay	$T_{\text{sync2clk}}$	162.8	285	-	ns
Setup to trailing edge of RESET# (ATE test mode) (Note 4)	$T_{\text{setup2rst}}$	15	-	-	ns
Rising edge of RESET# to Hi-Z delay (Note 4)	$T_{\text{off}}$	-	-	25	ns

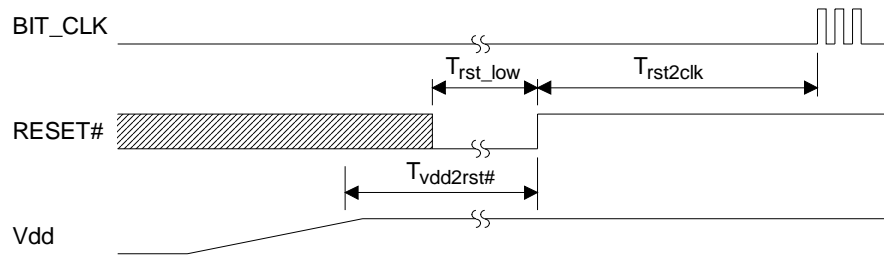

**Figure 1. Power Up Timing**

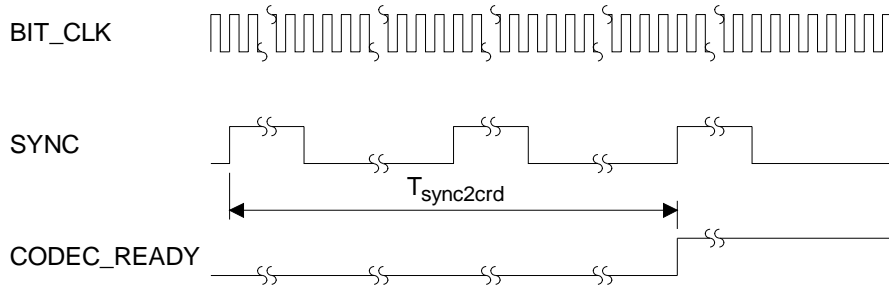

**Figure 2. Codec Ready from Start-up or Fault Condition**

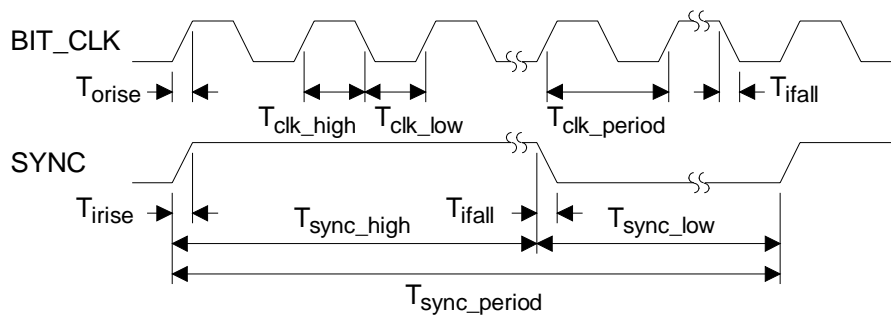

**Figure 3. Clocks**

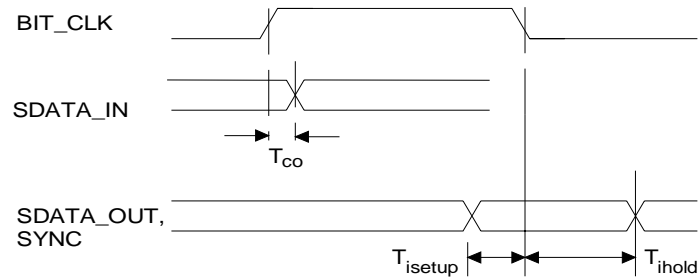

**Figure 4. Data Setup and Hold**

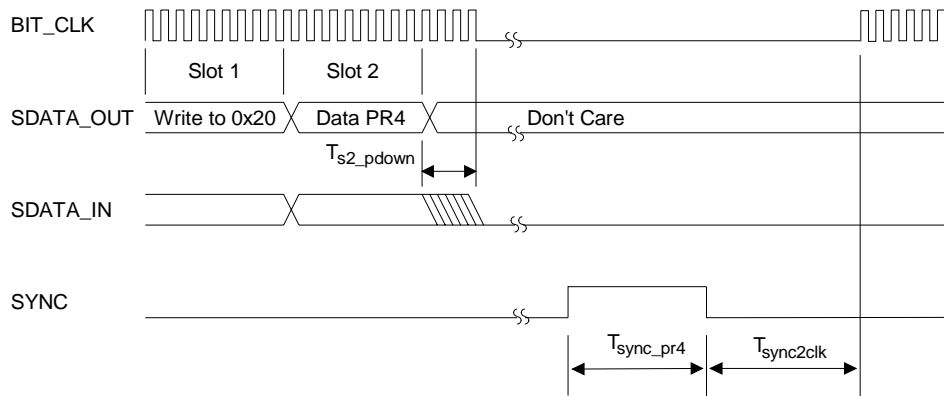

**Figure 5. PR4 Powerdown and Warm Reset**

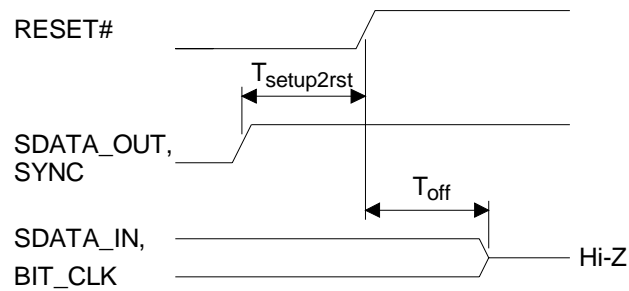

**Figure 6. Test Mode**

## 2. GENERAL DESCRIPTION

The CS4205 is a mixed-signal serial audio codec compliant with the Intel® *Audio Codec '97 Specification*, revision 2.1 [6] (referred to as AC '97). It is designed to be paired with a digital controller, typically located on the PCI bus or integrated within the system core logic chip set. The controller is responsible for all communications between the CS4205 and the remainder of the system. The CS4205 contains two distinct functional sections: digital and analog. The digital section includes the AC-link interface, S/PDIF interface, serial data port, GPIO, signal processing engine, ZV Port, power management support, and Sample Rate Converters (SRCs). The analog section includes the analog input multiplexer (mux), stereo input mixer, stereo output mixer, mono output mixer, stereo Analog-to-Digital Converters (ADCs), stereo Digital-to-Analog Converters (DACs), dedicated mono microphone ADC, and their associated volume controls.

### 2.1 AC-Link

All communication with the CS4205 is established with a 5-wire digital interface to the controller called the AC-link. This interface is shown in Figure 7. All clocking for the serial communication is synchronous to the BIT\_CLK signal. BIT\_CLK is generated by the primary audio codec and is used to clock the controller and any secondary audio codecs. Both input and output AC-link audio frames are organized as a sequence of 256 serial bits forming 13 groups referred to as 'slots'. During each audio frame, data is passed bi-directionally between the CS4205 and the controller. The input frame is driven from the CS4205 on the SDATA\_IN line. The output frame is driven from the controller on the SDATA\_OUT line. The controller is also responsible for issuing reset commands via the RESET# signal. Following a Cold Reset, the CS4205 is responsible for notifying the controller that it is ready for operation after synchronizing its internal functions. The CS4205 AC-link signals must use the same digital supply voltage as the controller, either +5 V or +3.3 V. See Section 4, *AC-Link Frame Definition*, for detailed AC-link information.

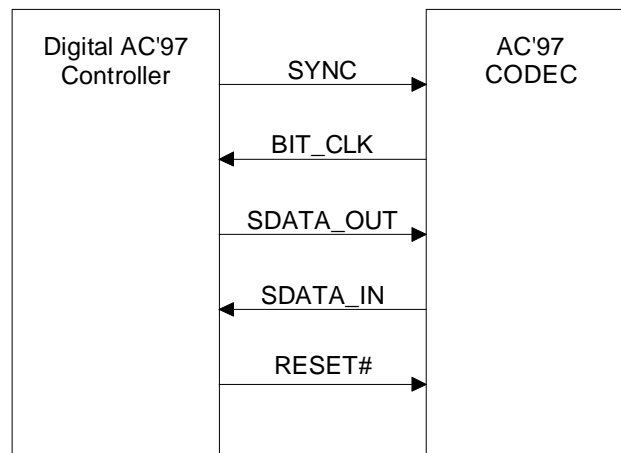

**Figure 7. AC-link Connections**

## 2.2 Control Registers

The CS4205 contains a set of AC '97 compliant control registers, and a set of Cirrus Logic defined control registers. These registers control the basic functions and features of the CS4205. Read accesses of the control registers by the AC '97 controller are accomplished with the requested register index in Slot 1 of a SDATA\_OUT frame. The following SDATA\_IN frame will contain the read data in Slot 2. Write operations are similar, with the register index in Slot 1 and the write data in Slot 2 of a SDATA\_OUT frame. The function of each input and output frame is detailed in Section 4, *AC-Link Frame Definition*. Individual register descriptions are found in Section 5, *Register Interface*.

## 2.3 Sample Rate Converters

The sample rate converters (SRC) provide high accuracy digital filters supporting sample frequencies other than 48 kHz to be captured from the CS4205 or played from the controller. AC '97 requires support for two audio rates (44.1 and 48 kHz) and four modem rates (8, 9.6, 13.714, and 16 kHz). In addition, the Intel® I/O Controller Hub (ICHx) specification [9] requires support for five more audio rates (8, 11.025, 16, 22.05, and 32 kHz) and specifies two optional modem rates (24, 48kHz). The CS4205 supports all these rates, as shown in Table 12 on page 38.

## 2.4 Mixers

The CS4205 input and output mixers are illustrated in Figure 8. The stereo input mixer sums together the analog inputs to the CS4205 according to the settings in the volume control registers. The stereo output mixer sums the output of the stereo input

mixer with the PC\_BEEP and PHONE signals. The stereo output mix is then sent to the LINE\_OUT pins of the CS4205. The mono output mixer generates a monophonic sum of the left and right audio channels from the stereo input mixer. The mono output mix is then sent to the MONO\_OUT pin on the CS4205.

## 2.5 Input Mux

The input multiplexer controls which analog input is sent to the ADCs. The output of the input mux is converted to stereo 18-bit digital PCM data and transmitted to the controller by means of the AC-link SDATA\_IN signal.

## 2.6 Volume Control

The CS4205 volume registers control analog input levels to the input mixer and analog output levels, including the master volume level. The PC\_BEEP volume control uses 3 dB steps with a range of 0 dB to -45 dB attenuation. All other analog volume controls use 1.5 dB steps. The analog inputs have a mixing range of +12 dB signal gain to -34.5 dB signal attenuation. The analog output volume controls have a range of 0 dB to -46.5 dB attenuation for LINE\_OUT and MONO\_OUT.

## 2.7 Dedicated Mic Record Path

The CS4205 includes a dedicated microphone ADC that supports advanced functions such as speech recognition and internet telephony. The dedicated ADC allows recording of a microphone input independent of the input mux settings. This enables simultaneous capture of microphone and independent stereo sources.

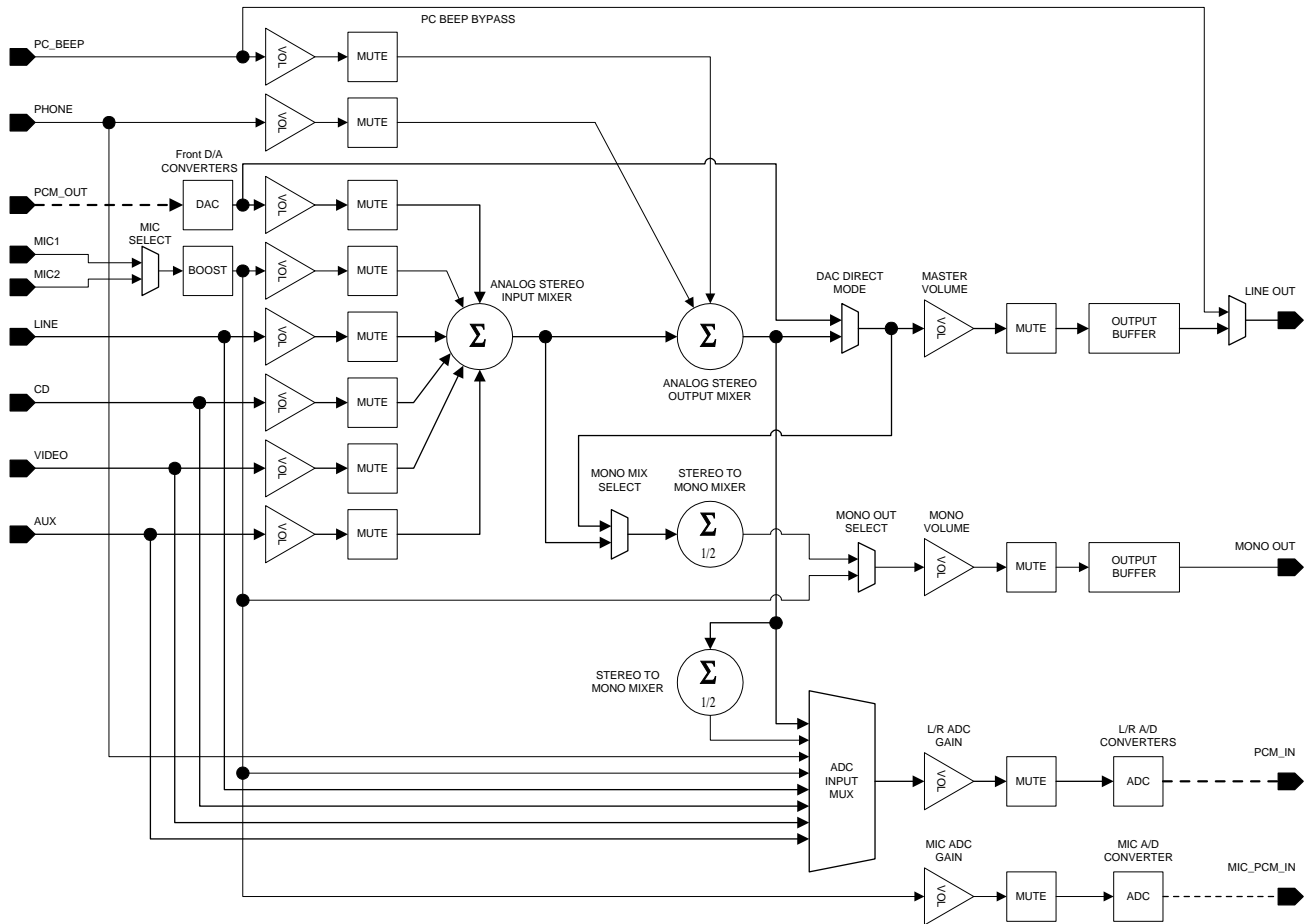

**Figure 8. CS4205 Mixer Diagram**

### 3. DIGITAL SIGNAL PATHS

The CS4205 includes a number of internal digital signal path options. Figure 9 shows the principal signal flow options through one channel of the device. Four commonly used signal flow modes are detailed in the following sections. The signal flow modes are controlled through the bits in the *AC Mode Control Register (Index 5Eh)*. The bit configuration for each detailed mode is listed in Table 1 on page 17.

#### 3.1 Analog Centric Mode

Analog centric mode is detailed in Figure 10 on page 18. In this mode, all the digital sources are pre-mixed in the digital mixer and sent to the DACs. The DAC outputs are mixed with the analog sources in the analog mixer. The ADCs send captured data directly to the host. The ADC mux is used to select a single source or the output of the input mixer for capture. In the analog centric mode, effects processing is only available on digital sources.

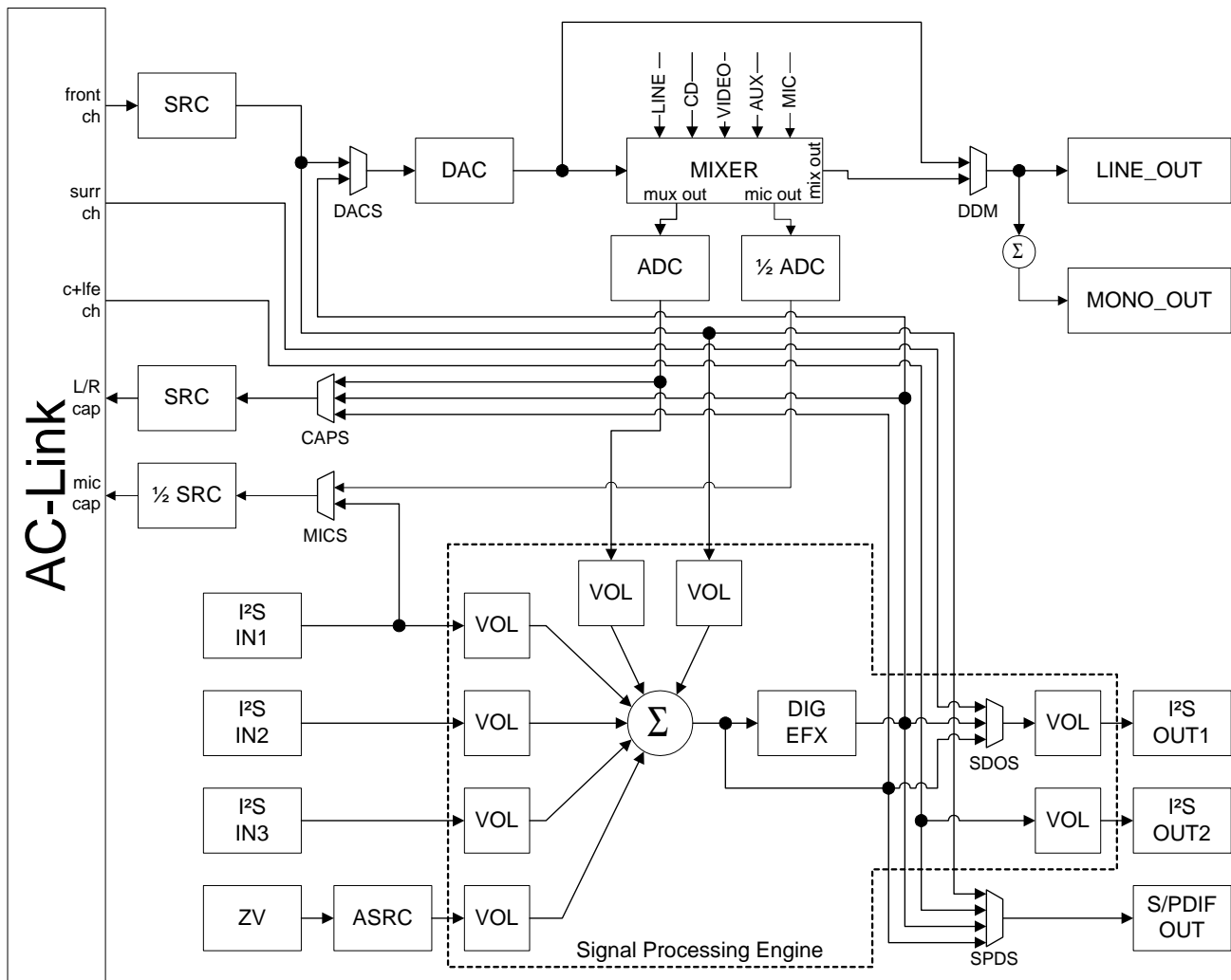

**Figure 9. Digital Signal Path Overview**



### 3.2 Digital Centric Mode

Digital centric mode is detailed in Figure 11. In this mode, the analog sources are first mixed in the analog mixer and sent to the ADCs. The ADC outputs are then mixed with the digital sources in the digital mixer. This allows effects processing on all sources and supports a “what you hear is what you record” model. The processed digital signal is sent to the DACs, bypassing the analog mixer using DAC direct mode. The ADC mux must be set to stereo mix to support this model. Consequently, only the mix can be captured by the host, rather than the individual sources.

### 3.3 Host Processing Mode

Host processing mode is detailed in Figure 12. This mode is similar to digital centric mode, except the

output of the digital mixer is captured by the host. Any mixing with host sources and effects processing is done on the host. The processed signal is sent to the DACs, bypassing the analog mixer using DAC direct mode. In host processing mode, the playback and capture paths are completely separate inside the CS4205.

### 3.4 Multi-Channel Mode

Multi-channel mode is detailed in Figure 13. This mode is an extension of any of the other three modes, with the distinguishing feature that one or two additional slot pairs are routed to the serial data output ports. This allows for a complete multi-channel solution with a single AC '97 audio codec and external DACs.

AC Mode Control Bits	Analog Centric Mode	Digital Centric Mode	Host Processing Mode	Multi-Channel Mode
DACS	1	1	0	0 or 1
CAPS[1:0]	00	10	10	00,10 or 11
MICS	0 or 1	0 or 1	0 or 1	0 or 1
DDM	0	1	1	0 or 1
SDOS[1:0]	10 or 11	11	-	00
SPDS[1:0]	00, 01, 10 or 11	00, 01, 10 or 11	00 or 01	N/A

**Table 1. AC Mode Control Configurations**

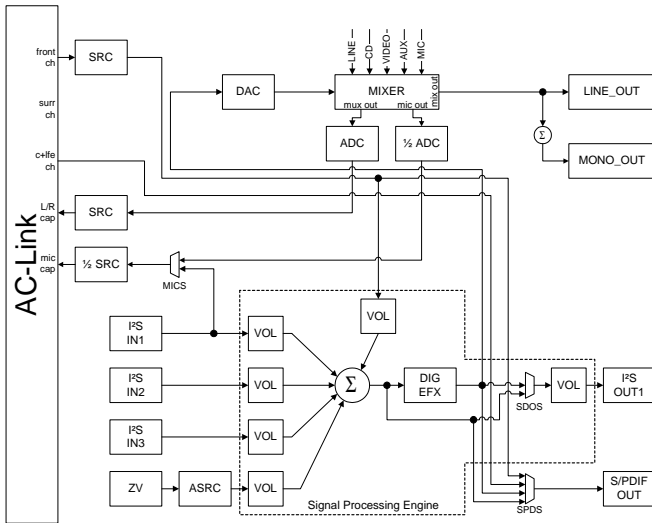
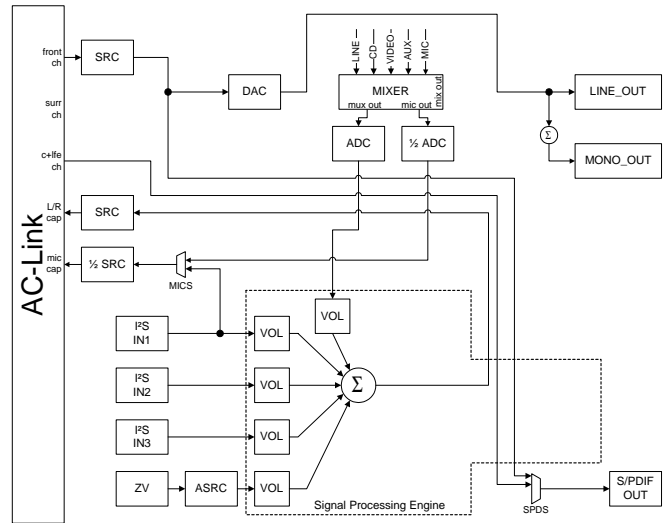
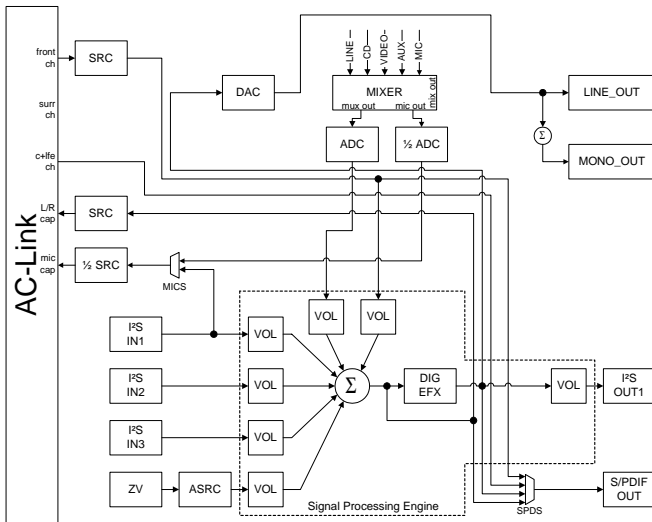
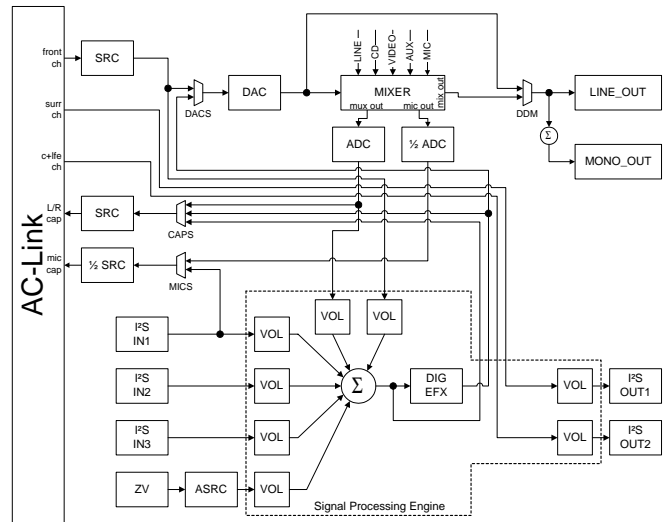
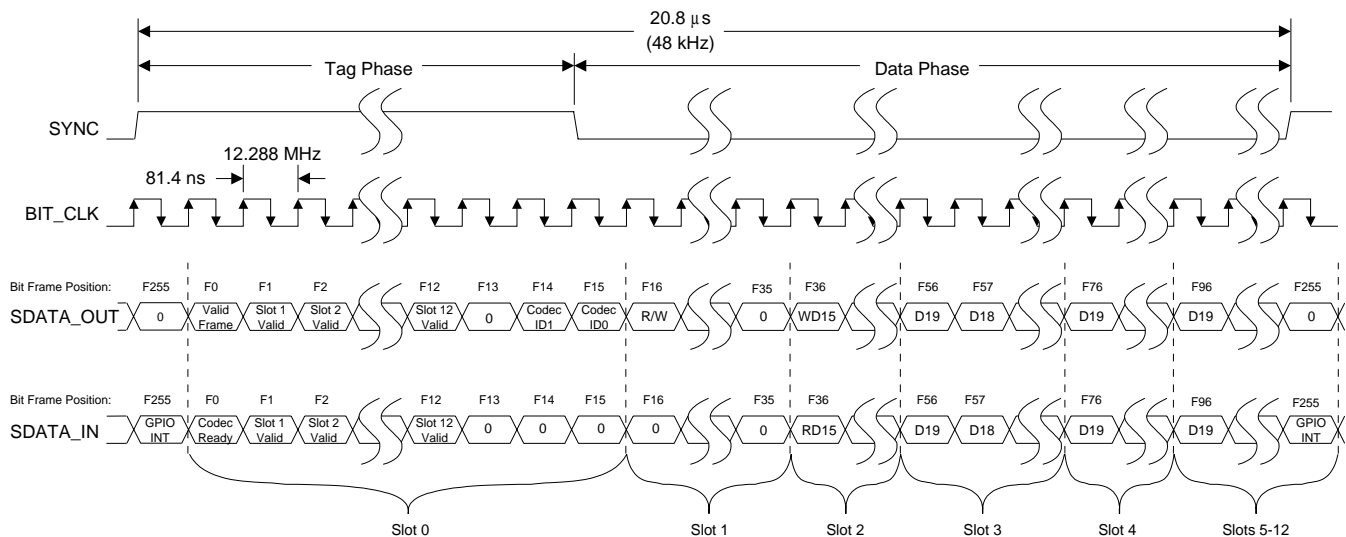

**Figure 10. Analog Centric Mode**

**Figure 12. Host Processing Mode**

**Figure 11. Digital Centric Mode**

**Figure 13. Multi-Channel Mode**

#### 4. AC-LINK FRAME DEFINITION

The AC-link is a bi-directional serial port with data organized into frames consisting of one 16-bit and twelve 20-bit time-division multiplexed slots. Slot 0 is a special reserved time slot containing 16-bits which are used for AC-link protocol infrastructure. Slots 1 through 12 contain audio or control/status data. Both the serial data output and input frames are defined from the controller perspective, not from the CS4205 perspective.

The controller synchronizes the beginning of a frame with the assertion of the SYNC signal. Figure 14 shows the position of each bit location

within the frame. The first bit position in a new serial data frame is F0 and the last bit position in the serial data frame is F255. When SYNC goes active (high) and is sampled active by the CS4205 (on the falling edge of BIT\_CLK), both devices are synchronized to a new serial data frame. The data on the SDATA\_OUT pin at this clock edge is the final bit of the previous frame's serial data. On the next rising edge of BIT\_CLK, the first bit of Slot 0 is driven by the controller on the SDATA\_OUT pin. On the next falling edge of BIT\_CLK, the CS4205 latches this data in as the first bit of the frame.



**Figure 14. AC-link Input and Output Framing**

## 4.1 AC-Link Serial Data Output Frame

In the serial data output frame, data is passed on the SDATA\_OUT pin to the CS4205 from the AC '97 controller. Figure 14 illustrates the serial port timing.

The PCM playback data being passed to the CS4205 is shifted out MSB first in the most significant bits of each slot. Any PCM data from the AC '97 controller that is not 20 bits wide should be left justified in its corresponding slot and dithered or zero-padded in the unused bit positions.

Bits that are reserved should always be 'cleared' by the AC '97 controller.

### 4.1.1 Serial Data Output Slot Tags (Slot 0)

Bit 15	14	13	12	11	10	9	8	7	6	5	4	3	2	1	0
Valid Frame	Slot 1 Valid	Slot 2 Valid	Slot 3 Valid	Slot 4 Valid	Slot 5 Valid	Slot 6 Valid	Slot 7 Valid	Slot 8 Valid	Slot 9 Valid	Slot 10 Valid	Slot 11 Valid	Slot 12 Valid	Res	Codec ID1	Codec ID0

**Valid Frame** The Valid Frame bit determines if any of the following slots contain either valid playback data for the CS4205 or data for read/write operations. When 'set', at least one of the other AC-link slots contains valid data. If this bit is 'clear', the remainder of the frame is ignored.

**Slot 1 Valid** The Slot 1 Valid bit indicates a valid register read/write address for a primary codec.

**Slot 2 Valid** The Slot 2 Valid bit indicates valid register write data for a primary codec.

**Slot [3:11] Valid** The Slot [3:11] Valid bits indicate the validity of data in their corresponding serial data output slots. If a bit is 'set', the corresponding output slot contains valid data. If a bit is 'cleared', the corresponding slot will be ignored.

**Slot 12 Valid** The Slot 12 Valid bit indicates if output Slot 12 contains valid GPIO control data.

**Codec ID[1:0]** The Codec ID[1:0] bits determine which codec is being accessed during the current AC-link frame. Codec ID[1:0] = 00 indicates the primary codec is being accessed. Codec ID[1:0] = 01, 10, or 11 indicates one of three possible secondary codecs is being accessed. A Codec ID value of 01, 10, or 11 also indicates a valid read/write address and/or valid register write data for a secondary codec.

### 4.1.2 Command Address Port (Slot 1)

Bit 19	18	17	16	15	14	13	12	11	10	9	8	7	6	5	4	3	2	1	0
R/W	RI6	RI5	RI4	RI3	RI2	RI1	RI0	Reserved											

**R/W** Read/Write. When this bit is 'set', a read of the AC '97 register specified by the register index bits will occur in the AC '97 2.x audio codec. When the bit is 'cleared', a write will occur. For any read or write access to occur, the Valid Frame bit (F0) must be 'set' and the Codec ID[1:0] bits (F[14:15]) must match the Codec ID of the AC '97 2.x audio codec being accessed. Additionally, for a primary codec, the Slot 1 Valid bit (F1) must be 'set' for a read access and both the Slot 1 Valid bit (F1) and the Slot 2 Valid bit (F2) must be 'set' for a write access. For a secondary codec, both the Slot 1 Valid bit (F1) and the Slot 2 Valid bit (F2) must be 'cleared' for read and write accesses. See Figure 14 for bit frame positions.

**RI[6:0]** Register Index. The RI[6:0] bits contain the 7-bit register index to the AC '97 registers in the CS4205. All registers are defined at word addressable boundaries. The RI0 bit must be 'clear' to access CS4205 registers.

### 4.1.3 Command Data Port (Slot 2)

Bit 19	18	17	16	15	14	13	12	11	10	9	8	7	6	5	4	3	2	1	0
WD15	WD14	WD13	WD12	WD11	WD10	WD9	WD8	WD7	WD6	WD5	WD4	WD3	WD2	WD1	WD0	Reserved			

WD[15:0] Write Data. The WD[15:0] bits contain the 16-bit value to be written to the register. If an access is a read, this slot is ignored.

NOTE: For any write to an AC '97 register, the write is defined to be an 'atomic' access. This means that when the Slot 1 Valid bit in output Slot 0 is 'set', the Slot 2 Valid bit in output Slot 0 should always be 'set' during the same audio frame. No write access may be split across 2 frames.

### 4.1.4 PCM Playback Data (Slots 3-11)

Bit 19	18	17	16	15	14	13	12	11	10	9	8	7	6	5	4	3	2	1	0
PD19	PD18	PD17	PD16	PD15	PD14	PD13	PD12	PD11	PD10	PD9	PD8	PD7	PD6	PD5	PD4	PD3	PD2	PD1	PD0

PD[19:0] Playback Data. The PD[19:0] bits contain the 20-bit PCM (2's complement) playback data for the left and right DACs, serial data ports, and/or the S/PDIF transmitter. Table 14 on page 43 lists a cross reference for each function and its respective slot. The mapping of a given slot to the DAC, serial data port, or S/PDIF transmitter is determined by the state of the ID[1:0] bits in the *Extended Audio ID Register (Index 28h)* and by the SM[1:0] and AMAP bits in the *AC Mode Control Register (Index 5Eh)*.

### 4.1.5 GPIO Pin Control (Slot12)

Bit 19	18	17	16	15	14	13	12	11	10	9	8	7	6	5	4	3	2	1	0
Not Implemented											GPIO4	GPIO3	GPIO2	GPIO1	GPIO0	Reserved			

GPIO[4:0] GPIO Pin Control. The GPIO[4:0] bits control the CS4205 GPIO pins configured as outputs. Write accesses using GPIO pin control bits configured as outputs will be reflected on the GPIO pin output on the next AC-link frame. Write accesses using GPIO pin control bits configured as inputs will have no effect and are ignored. If the GPOC bit in the *Misc. Crystal Control Register (Index 60h)* is 'set', the bits in output Slot 12 are ignored and GPIO pins configured as outputs are controlled through the *GPIO Pin Status Register (Index 54h)*.

## 4.2 AC-Link Serial Data Input Frame

In the serial data input frame, data is passed on the SDATA\_IN pin from the CS4205 to the AC '97 controller. The data format for the input frame is very similar to the output frame. Figure 14 on page 19 illustrates the serial port timing.

The PCM capture data from the CS4205 is shifted out MSB first in the most significant 18 bits of each slot. The least significant 2 bits in each slot will be 'cleared'. If the host requests PCM data from the AC '97 Controller that is less than 18 bits wide, the controller should dither and round or just round (but not truncate) to the desired bit depth.

Bits that are reserved or not implemented in the CS4205 will always be returned 'cleared'.

### 4.2.1 Serial Data Input Slot Tag Bits (Slot 0)

Bit 15	14	13	12	11	10	9	8	7	6	5	4	3	2	1	0
Codec Ready	Slot 1 Valid	Slot 2 Valid	Slot 3 Valid	Slot 4 Valid	Slot 5 Valid	Slot 6 Valid	Slot 7 Valid	Slot 8 Valid	0	0	Slot 11 Valid	Slot 12 Valid	Reserved		

**Codec Ready**      Codec Ready. The Codec Ready bit indicates the readiness of the CS4205 AC-link. Immediately after a Cold Reset this bit will be 'clear'. Once the CS4205 clocks and voltages are stable, this bit will be 'set'. Until the Codec Ready bit is 'set', no AC-link transactions should be attempted by the controller. The Codec Ready bit does not indicate readiness of the DACs, ADCs, Vref, or any other analog function. Those must be checked in the *Powerdown Control/Status Register (Index 26h)* by the controller before any access is made to the mixer registers. Any accesses to the CS4205 while Codec Ready is 'clear' are ignored.

**Slot 1 Valid**      The Slot 1 Valid bit indicates Slot 1 contains a valid read back address.

**Slot 2 Valid**      The Slot 2 Valid bit indicates Slot 2 contains valid register read data.

**Slot [3:8,11] Valid**      The Slot [3:8,11] Valid bits indicate Slot [3:8,11] contains valid capture data from the CS4205 ADCs. If a bit is 'set', the corresponding input slot contains valid data. If a bit is 'cleared', the corresponding slot will be ignored.

**Slot 12 Valid**      The Slot 12 Valid bit indicates Slot 12 contains valid GPIO status data.

### 4.2.2 Status Address Port (Slot 1)

Bit 19	18	17	16	15	14	13	12	11	10	9	8	7	6	5	4	3	2	1	0
Res	RI6	RI5	RI4	RI3	RI2	RI1	RI0	SR3	SR4	SR5	SR6	SR7	SR8	SR9	0	SR11	0	Reserved	

**RI[6:0]**      Register Index. The RI[6:0] bits echo the AC '97 register address when a register read has been requested in the previous frame. The CS4205 will only echo the register index for a read access. Write accesses will not return valid data in Slot 1.

**SR[3:9,11]**      Slot Request. If SR<sub>x</sub> is 'set', this indicates the CS4205 SRC does not need a new sample on the next AC-link frame for that particular slot. If SR<sub>x</sub> is 'clear', the SRC indicates a new sample is needed on the following frame. If the VRA bit in the *Extended Audio Status/Control Register (Index 2Ah)* is 'clear', the SR[3:9,11] bits are always 0. When VRA is 'set', the SRC is enabled and the SR[3:9,11] bits are used to request data.

### 4.2.3 Status Data Port (Slot 2)

Bit 19	18	17	16	15	14	13	12	11	10	9	8	7	6	5	4	3	2	1	0
RD15	RD14	RD13	RD12	RD11	RD10	RD9	RD8	RD7	RD6	RD5	RD4	RD3	RD2	RD1	RD0	Reserved			

**RD[15:0]** Read Data. The RD[15:0] bits contain the register data requested by the controller from the previous read request. All read requests will return the read address in the input Slot 1 and the register data in the input Slot 2 on the following serial data frame.

### 4.2.4 PCM Capture Data (Slot 3-8,11)

Bit 19	18	17	16	15	14	13	12	11	10	9	8	7	6	5	4	3	2	1	0
CD17	CD16	CD15	CD14	CD13	CD12	CD11	CD10	CD9	CD8	CD7	CD6	CD5	CD4	CD3	CD2	CD1	CD0	0	0

**CD[17:0]** Capture Data. The CD [17:0] bits contain 18-bit PCM (2's complement) capture data. The data will only be valid when the respective slot valid bit is 'set' in input Slot 0. The mapping of a given slot to an ADC is determined by the state of the ID[1:0] bits in the *Extended Audio ID Register (Index 28h)* and the SM[1:0] and AMAP bits in the *AC Mode Control Register (Index 5Eh)*. The definition of each slot can be found in Table 14 on page 43.

### 4.2.5 GPIO Pin Status (Slot 12)

Bit 19	18	17	16	15	14	13	12	11	10	9	8	7	6	5	4	3	2	1	0
0	0	0	0	0	0	0	0	0	0	0	GPIO4	GPIO3	GPIO2	GPIO1	GPIO0	Res	BDI	IEC	GPIO_INT

**GPIO[4:0]** GPIO Pin Status. The GPIO[4:0] bits reflect the status of the CS4205 GPIO pins configured as inputs. The pin status of GPIO pins configured as outputs will be reflected back on the GPIO[4:0] bits of input Slot 12 in the next frame. The output GPIO pins are controlled by the GPIO[4:0] pin control bits in output Slot 12.

**BDI** BIOS-Driver Interface. The BDI bit indicates that a BIOS event has occurred. This bit is a logic OR of all bits in the *BDI Status Register (Index 7Ah)* ANDed with their corresponding bit in the *BDI Config Register (Index 6Eh, Address 0Ch)*.

**IEC** Internal Error Condition. The IEC bit indicates that an internal error, such as an ADC over-range or a digital data overflow has occurred. This bit is a logic OR of all bits in the *IEC Status Register (Index 6Eh, Address 0Bh)*.

**GPIO\_INT** GPIO Interrupt. The GPIO\_INT bit indicates that a GPIO, BDI, or IEC interrupt event has occurred. The occurrence of a GPIO interrupt is determined by the GPIO interrupt requirements as outlined in the *GPIO Pin Wakeup Mask Register (Index 52h)* description. In this case, the GPIO\_INT bit is cleared by writing a '0' to the bit in the *GPIO Pin Status Register (Index 54h)* corresponding to the GPIO pin which generated the interrupt.

The occurrence of a BDI interrupt is determined by the BDI interrupt requirements as outlined in the *BDI Control Registers (Index 6Eh, Address 0Ch - 0Dh)*. In this case, the GPIO\_INT bit is cleared by writing a '0' to the bit in the *BDI Status Register (Index 7Ah)* that generated the interrupt.

The occurrence of an IEC interrupt is determined by the IEC interrupt requirements as outlined in the *Internal Error Condition Control/Status Registers (Index 6Eh, Address 09h - 0Bh)*. In this case, the GPIO\_INT bit is cleared by writing a '0' to the bit in the *IEC Status Register (Index 6Eh, Address 0Bh)* corresponding to the IEC source which generated the interrupt.

### 4.3 AC-Link Protocol Violation - Loss of SYNC

The CS4205 is designed to handle SYNC protocol violations. The following are situations where the SYNC protocol has been violated:

- The SYNC signal is not sampled high for exactly 16 BIT\_CLK clock cycles at the start of an audio frame.
- The SYNC signal is not sampled high on the 256th BIT\_CLK clock period after the previous SYNC assertion.

- The SYNC signal goes active high before the 256th BIT\_CLK clock period after the previous SYNC assertion.

Upon loss of synchronization with the controller, the CS4205 will 'clear' the Codec Ready bit in the serial data input frame until two valid frames are detected. During this detection period, the CS4205 will ignore all register reads and writes and will discontinue the transmission of PCM capture data. In addition, if the LOSM bit in the *Misc. Crystal Control Register (Index 60h)* is 'set' (default), the CS4205 will mute all analog outputs. If the LOSM bit is 'clear', the analog outputs will not be muted.



**5. REGISTER INTERFACE**

Reg	Register Name	D15	D14	D13	D12	D11	D10	D9	D8	D7	D6	D5	D4	D3	D2	D1	D0	Default
00h	Reset	0	SE4	SE3	SE2	SE1	SE0	0	ID8	ID7	0	ID5	0	ID3	ID2	0	ID0	25ADh
02h	Master Volume	Mute	0	ML5	ML4	ML3	ML2	ML1	ML0	0	0	MR5	MR4	MR3	MR2	MR1	MR0	8000h
06h	Mono Volume	Mute	0	0	0	0	0	0	0	0	0	MM5	MM4	MM3	MM2	MM1	MM0	8000h
08h	Master Tone Control	0	0	0	0	BA3	BA2	BA1	BA0	0	0	0	0	TR3	TR2	TR1	TR0	0F0Fh
0Ah	PC_BEEP Volume	Mute	0	0	0	0	0	0	0	0	0	0	PV3	PV2	PV1	PV0	0	0000h
0Ch	Phone Volume	Mute	0	0	0	0	0	0	0	0	0	0	GN4	GN3	GN2	GN1	GN0	8008h
0Eh	Mic Volume	Mute	0	0	0	0	0	0	0	0	20dB	0	GN4	GN3	GN2	GN1	GN0	8008h
10h	Line In Volume	Mute	0	0	GL4	GL3	GL2	GL1	GL0	0	0	0	GR4	GR3	GR2	GR1	GR0	8808h
12h	CD Volume	Mute	0	0	GL4	GL3	GL2	GL1	GL0	0	0	0	GR4	GR3	GR2	GR1	GR0	8808h
14h	Video Volume	Mute	0	0	GL4	GL3	GL2	GL1	GL0	0	0	0	GR4	GR3	GR2	GR1	GR0	8808h
16h	Aux Volume	Mute	0	0	GL4	GL3	GL2	GL1	GL0	0	0	0	GR4	GR3	GR2	GR1	GR0	8808h
18h	PCM Out Volume	Mute	0	0	GL4	GL3	GL2	GL1	GL0	0	0	0	GR4	GR3	GR2	GR1	GR0	8808h
1Ah	Record Select	0	0	0	0	0	SL2	SL1	SL0	0	0	0	0	0	SR2	SR1	SR0	0000h
1Ch	Record Gain	Mute	0	0	0	GL3	GL2	GL1	GL0	0	0	0	0	GR3	GR2	GR1	GR0	8000h
1Eh	Record Gain Mic	Mute	0	0	0	0	0	0	0	0	0	0	0	GM3	GM2	GM1	GM0	8000h
20h	General Purpose	POP	ST	3D	LD	0	0	MIX	MS	LPBK	0	0	0	0	0	0	0	0000h
22h	3D Control	0	0	0	0	CR3	CR2	CR1	CR0	0	0	0	0	DP3	DP2	DP1	DP0	0000h
26h	Powerdown Ctrl/Stat	EAPD	0	PR5	PR4	PR3	PR2	PR1	PR0	0	0	0	0	REF	ANL	DAC	ADC	000Fh
28h	Ext'd Audio ID	ID1	ID0	0	0	0	0	AMAP	0	0	0	0	0	VRM	0	0	VRA	x209h
2Ah	Ext'd Audio Stat/Ctrl	0	PRL	0	0	0	0	MADC	0	0	0	0	0	VRM	0	0	VRA	4000h
2Ch	PCM Front DAC Rate	SR15	SR14	SR13	SR12	SR11	SR10	SR9	SR8	SR7	SR6	SR5	SR4	SR3	SR2	SR1	SR0	BB80h
32h	PCM L/R ADC Rate	SR15	SR14	SR13	SR12	SR11	SR10	SR9	SR8	SR7	SR6	SR5	SR4	SR3	SR2	SR1	SR0	BB80h
34h	Mic ADC Rate	SR15	SR14	SR13	SR12	SR11	SR10	SR9	SR8	SR7	SR6	SR5	SR4	SR3	SR2	SR1	SR0	BB80h
3Ch	Ext'd Modem ID	ID1	ID0	0	0	0	0	0	0	0	0	0	0	0	0	0	0	x000h
3Eh	Ext'd Modem Stat/Ctrl	0	0	0	0	0	0	0	PRA	0	0	0	0	0	0	0	GPIO	0100h
4Ch	GPIO Pin Config.	0	0	0	0	0	0	0	0	0	0	0	GC4	GC3	GC2	GC1	GC0	001Fh
4Eh	GPIO Pin Polarity/Type	1	1	1	1	1	1	1	1	1	1	1	GP4	GP3	GP2	GP1	GP0	FFFFh
50h	GPIO Pin Sticky	0	0	0	0	0	0	0	0	0	0	0	GS4	GS3	GS2	GS1	GS0	0000h
52h	GPIO Pin Wakeup	0	0	0	0	0	0	0	0	0	0	0	GW4	GW3	GW2	GW1	GW0	0000h
54h	GPIO Pin Status	0	0	0	0	0	0	0	0	0	0	0	GI4	GI3	GI2	GI1	GI0	0000h
<b>Cirrus Logic Defined Registers:</b>																		
5Eh	AC Mode Control	DACS	CAPS1	CAPS0	MICS	0	0	TMM	DDM	AMAP	0	SM1	SM0	SDOS1	SDOS0	SPDS1	SPDS0	0080h
60h	Misc. Crystal Control	0	0	Res	DPC	0	0	Reserved	10dB	CRST	Reserved	GPOC	Reserved	LOSM	0003h			
68h	S/PDIF Control	SPEN	Val	0	Fs	L	CC6	CC5	CC4	CC3	CC2	CC1	CC0	Emph	Copy	/Audio	Pro	0000h
6Ah	Serial Port Control	SDEN	0	0	0	0	0	0	0	SDI3	SDI2	SDI1	SDO2	SDSC	SDF1	SDF0	0000h	
6Ch	Special Feature Addr	0	0	0	0	0	0	0	0	0	0	0	A3	A2	A1	A0	0000h	
6Eh	Special Feature Data	D15	D14	D13	D12	D11	D10	D9	D8	D7	D6	D5	D4	D3	D2	D1	D0	8000h
7Ah	BDI Status	E15	E14	E13	E12	E11	E10	E9	E8	E7	E6	E5	E4	E3	E2	E1	E0	0000h
7Ch	Vendor ID1	F7	F6	F5	F4	F3	F2	F1	F0	S7	S6	S5	S4	S3	S2	S1	S0	4352h
7Eh	Vendor ID2	T7	T6	T5	T4	T3	T2	T1	T0	0	DID2	DID1	DID0	1	REV2	REV1	REV0	5959h

**Table 2. Register Overview for the CS4205**

Reg	Register Name	D15	D14	D13	D12	D11	D10	D9	D8	D7	D6	D5	D4	D3	D2	D1	D0	Default
00h	PCM Input Volume	Mute	0	GL5	GL4	GL3	GL2	GL1	GL0	0	0	GR5	GR4	GR3	GR2	GR1	GR0	8000h
01h	ADC Input Volume	Mute	0	GL5	GL4	GL3	GL2	GL1	GL0	0	0	GR5	GR4	GR3	GR2	GR1	GR0	8000h
02h	SDI1 Volume	Mute	0	GL5	GL4	GL3	GL2	GL1	GL0	0	0	GR5	GR4	GR3	GR2	GR1	GR0	8000h
03h	SDI2 Volume	Mute	0	GL5	GL4	GL3	GL2	GL1	GL0	0	0	GR5	GR4	GR3	GR2	GR1	GR0	8000h
04h	SDI3 Volume	Mute	0	GL5	GL4	GL3	GL2	GL1	GL0	0	0	GR5	GR4	GR3	GR2	GR1	GR0	8000h
05h	ZV Volume	Mute	0	GL5	GL4	GL3	GL2	GL1	GL0	0	0	GR5	GR4	GR3	GR2	GR1	GR0	8000h
06h	SDOUT Volume	Mute	0	GL5	GL4	GL3	GL2	GL1	GL0	0	0	GR5	GR4	GR3	GR2	GR1	GR0	8000h
07h	SDO2 Volume	Mute	0	GL5	GL4	GL3	GL2	GL1	GL0	0	0	GR5	GR4	GR3	GR2	GR1	GR0	8000h
08h	SP Engine Control	Res	SDI1M	SRZC1	SRZC0	LPFS1	LPFS0	HPFS1	HPFS0	GL3	GL2	GL1	GL0	GR3	GR2	GR1	GR0	1800h
09h	IEC Config	EROF	ELOF	MROF	MLOF	0	AMOR	AROR	ALOR	0	0	0	0	0	0	0	0	0000h
0Ah	IEC Wakeup	EROF	ELOF	MROF	MLOF	0	AMOR	AROR	ALOR	0	0	0	0	0	0	0	0	0000h
0Bh	IEC Status	EROF	ELOF	MROF	MLOF	0	AMOR	AROR	ALOR	0	0	0	0	0	0	0	0	0000h
0Ch	BDI Config	E15	E14	E13	E12	E11	E10	E9	E8	E7	E6	E5	E4	E3	E2	E1	E0	0000h
0Dh	BDI Wakeup	E15	E14	E13	E12	E11	E10	E9	E8	E7	E6	E5	E4	E3	E2	E1	E0	0000h
0Eh	ZV Port Ctrl/Stat 1	ZVEN	LOCK	0	Ph24	Ph23	Ph22	Ph21	Ph20	Ph19	Ph18	Ph17	Ph16	Ph15	Ph14	Ph13	Ph12	0000h
0Fh	ZV Port Ctrl/Stat 2	Reserved				Ph11	Ph10	Ph9	Ph8	Ph7	Ph6	Ph5	Ph4	Ph3	Ph2	Ph1	Ph0	0000h

**Table 3. Indirectly Addressed Register Overview**

### 5.1 Reset Register (Index 00h)

D15	D14	D13	D12	D11	D10	D9	D8	D7	D6	D5	D4	D3	D2	D1	D0
0	SE4	SE3	SE2	SE1	SE0	0	ID8	ID7	0	ID5	0	ID3	ID2	0	ID0

- SE[4:0] SRS 3D Stereo Enhancement. SE[4:0] = 01001, indicating this feature is present.
- ID8 18-bit ADC Resolution. The ID8 bit is 'set', indicating this feature is present.
- ID7 20-bit DAC resolution. The ID7 bit is 'set', indicating this feature is present.
- ID5 Loudness. The ID5 bit is 'set', indicating this feature is present.
- ID3 Simulated Stereo. The ID3 bit is 'set', indicating this feature is present.
- ID2 Bass & Treble. The ID2 bit is 'set', indicating this feature is present.
- ID0 Dedicated Mic PCM in Channel. The ID0 bit is 'set', indicating this feature is present.
- Default 25ADh. The data in this register is read-only data.

Any write to this register causes a Register Reset of the audio control (Index 00h - 3Ah) and Cirrus Logic defined (Index 5Ah - 7Ah) registers. A read from this register returns configuration information about the CS4205.

### 5.2 Master Volume Register (Index 02h)

D15	D14	D13	D12	D11	D10	D9	D8	D7	D6	D5	D4	D3	D2	D1	D0
Mute	0	<u>ML5</u>	ML4	ML3	ML2	ML1	ML0	0	0	<u>MR5</u>	MR4	MR3	MR2	MR1	MR0

- Mute Master Mute. Setting this bit mutes the LINE\_OUT\_L/R output signals.
- ML[5:0] Master Volume Left. These bits control the left master output volume. Each step corresponds to 1.5 dB gain adjustment, with a total available range from 0 dB to -46.5 dB attenuation. Setting the ML5 bit sets the left channel attenuation to -46.5 dB by forcing ML[4:0] to a '1' state. ML[5:0] will read back 011111 when ML5 has been 'set'. See Table 4 for further details.
- MR[5:0] Master Volume Right. These bits control the right master output volume. Each step corresponds to 1.5 dB gain adjustment, with a total available range from 0 dB to -46.5 dB attenuation. Setting the MR5 bit sets the right channel attenuation to -46.5 dB by forcing MR[4:0] to a '1' state. MR[5:0] will read back 011111 when MR5 has been 'set'. See Table 4 for further details.
- Default 8000h. This value corresponds to 0 dB attenuation and Mute 'set'.

Mx5 - Mx0 Write	Mx5 - Mx0 Read	Gain Level
000000	000000	0 dB
000001	000001	-1.5 dB
...	...	...
011111	011111	-46.5 dB
100000	011111	-46.5 dB
...	...	...
111111	011111	-46.5 dB

**Table 4. Analog Mixer Output Attenuation**

### 5.3 Mono Volume Register (Index 06h)

D15	D14	D13	D12	D11	D10	D9	D8	D7	D6	D5	D4	D3	D2	D1	D0
Mute	0	0	0	0	0	0	0	0	0	<u>MM5</u>	MM4	MM3	MM2	MM1	MM0

**Mute** Mono Mute. Setting this bit mutes the MONO\_OUT output signal.

**MM[5:0]** Mono Volume Control. The MM[5:0] bits control the mono output volume. Each step corresponds to 1.5 dB gain adjustment, with a total available range from 0 dB to -46.5 dB attenuation. Setting the MM5 bit sets the mono attenuation to -46.5 dB by forcing MM[4:0] to a '1' state. MM[5:0] will read back 011111 when MM5 has been 'set'. See Table 4 on page 27 for further attenuation levels.

**Default** 8000h. This value corresponds to 0 dB attenuation and Mute 'set'.

### 5.4 Master Tone Control Register (Index 08h)

D15	D14	D13	D12	D11	D10	D9	D8	D7	D6	D5	D4	D3	D2	D1	D0
0	0	0	0	BA3	BA2	BA1	BA0	0	0	0	0	TR3	TR2	TR1	TR0

**BA[3:0]** Bass Control. The BA[3:0] bits are used to control the bass gain in the effects engine. Each step corresponds to 1.5 dB gain adjustment, with a total available range from +10.5 dB to -10.5 dB gain. See Table 5 for further details. The center frequency from which the gain is measured defaults to 100 Hz for bass, and may be changed using the LPFS[1:0] bits in the *Signal Processing Engine Control Register (Index 6Eh, Address 08h)*.

**TR[3:0]** Treble Control. The TR[3:0] bits are used to control the treble gain in the effects engine. Each step corresponds to 1.5 dB gain adjustment, with a total available range from +10.5 dB to -10.5 dB gain. See Table 5 for further details. The center frequency from which the gain is measured defaults to 10 kHz for treble, and may be changed using the HPFS[1:0] bits in the *Signal Processing Engine Control Register (Index 6Eh, Address 08h)*.

**Default** 0F0Fh. This value corresponds to bypass of bass and treble gain.

TR3..TR0 BA3..BA0	Gain Level
0000	+10.5 dB
0001	+9 dB
...	...
0110	+1.5 dB
0111	0 dB
1000	-1.5 dB
...	...
1101	-9 dB
1110	-10.5 dB
1111	bypass

**Table 5. Tone Control Values**

### 5.5 PC\_BEEP Volume Register (Index 0Ah)

D15	D14	D13	D12	D11	D10	D9	D8	D7	D6	D5	D4	D3	D2	D1	D0
Mute	0	0	0	0	0	0	0	0	0	0	PV3	PV2	PV1	PV0	0

**Mute** PC\_BEEP Mute. Setting this bit mutes the PC\_BEEP input signal.

**PV[3:0]** PC\_BEEP Volume Control. The PV[3:0] bits control the gain levels of the PC\_BEEP input source to the Input Mixer. Each step corresponds to 3 dB gain adjustment, with 0000 = 0 dB. The total range is 0 dB to -45 dB attenuation.

**Default** 0000h. This value corresponds to 0 dB attenuation and Mute 'clear'.

This register has no effect on the PC\_BEEP volume during RESET#.

### 5.6 Phone Volume Register (Index 0Ch)

D15	D14	D13	D12	D11	D10	D9	D8	D7	D6	D5	D4	D3	D2	D1	D0
Mute	0	0	0	0	0	0	0	0	0	0	GN4	GN3	GN2	GN1	GN0

**Mute** Phone Mute. Setting this bit mutes the Phone input signal.

**GN[5:0]** Phone Volume Control. The GN[4:0] bits control the gain level of the Phone input source to the Input Mixer. Each step corresponds to 1.5 dB gain adjustment, with 01000 = 0 dB. The total range is +12 dB to -34.5 dB attenuation. See Table 7 on page 31 for further attenuation levels.

**Default** 8008h. This value corresponds to 0 dB attenuation and Mute 'set'.

### 5.7 Microphone Volume Register (Index 0Eh)

D15	D14	D13	D12	D11	D10	D9	D8	D7	D6	D5	D4	D3	D2	D1	D0
Mute	0	0	0	0	0	0	0	0	20dB	0	GN4	GN3	GN2	GN1	GN0

- Mute** Microphone Mute. Setting this bit mutes the MIC1 or MIC2 signal. The selection of the MIC1 or MIC2 input pin is controlled by the MS bit in the *General Purpose Register (Index 20h)*.
- 20dB** Microphone 20 dB Boost. When 'set', the 20dB bit enables the +20 dB microphone boost block. In combination with the 10dB boost bit in the *Misc. Crystal Control Register (Index 60h)* this bit allows for variable boost from 0 dB to +30 dB in steps of 10 dB. Table 6 summarizes this behavior.
- GN[4:0]** Microphone Volume Control. The GN[4:0] bits are used to control the gain level of the Microphone input source to the Input Mixer. Each step corresponds to 1.5 dB gain adjustment, with 01000 = 0 dB. The total range is +12 dB to -34.5 dB gain. See Table 6 for further details.
- Default** 8008h. This value corresponds to 0 dB gain and Mute 'set'.

GN4 - GN0	Gain Level			
	10dB = 0, 20dB = 0	10dB = 1, 20dB = 0	10dB = 0, 20dB = 1	10dB = 1, 20dB = 1
00000	+12.0 dB	+22.0 dB	+32.0 dB	+42.0 dB
00001	+10.5 dB	+20.5 dB	+30.5 dB	+40.5 dB
...	...	...	...	...
00111	+1.5 dB	+11.5 dB	+21.5 dB	+31.5 dB
01000	0.0 dB	+10.0 dB	+20.0 dB	+30.0 dB
01001	-1.5 dB	+8.5 dB	+18.5 dB	+28.5 dB
...	...	...	...	...
11111	-34.5 dB	-24.5 dB	-14.5 dB	-4.5 dB

**Table 6. Microphone Input Gain Values**

### 5.8 Analog Mixer Input Gain Registers (Index 10h - 18h)

D15	D14	D13	D12	D11	D10	D9	D8	D7	D6	D5	D4	D3	D2	D1	D0
Mute	0	0	GL4	GL3	GL2	GL1	GL0	0	0	0	GR4	GR3	GR2	GR1	GR0

**Mute** Stereo Input Mute. Setting this bit mutes the respective input signal, both right and left inputs.

**GL[4:0]** Left Volume Control. The GL[4:0] bits are used to control the gain level of the left analog input source to the Input Mixer. Each step corresponds to 1.5 dB gain adjustment, with 01000 = 0 dB. The total range is +12 dB to -34.5 dB gain. See Table 7 for further details.

**GR[4:0]** Right Volume Control. The GR[4:0] bits are used to control the gain level of the right analog input source to the Input Mixer. Each step corresponds to 1.5 dB gain adjustment, with 01000 = 0 dB. The total range is +12 dB to -34.5 dB gain. See Table 7 for further details.

**Default** 8808h. This value corresponds to 0 dB gain and Mute 'set'.

The Analog Mixer Input Gain Registers are listed in Table 8.

Gx4 - Gx0	Gain Level
00000	+12.0 dB
00001	+10.5 dB
...	...
00111	+1.5 dB
01000	0.0 dB
01001	-1.5 dB
...	...
11111	-34.5 dB

**Table 7. Analog Mixer Input Gain Values**

Register Index	Function
10h	Line In Volume
12h	CD Volume
14h	Video Volume
16h	Aux Volume
18h	PCM Out Volume

**Table 8. Analog Mixer Input Gain Register Index**

**5.9 Input Mux Select Register (Index 1Ah)**

D15	D14	D13	D12	D11	D10	D9	D8	D7	D6	D5	D4	D3	D2	D1	D0
0	0	0	0	0	SL2	SL1	SL0	0	0	0	0	0	SR2	SR1	SR0

SL[2:0] Left Channel Source. The SL[2:0] bits select the left channel source to pass to the ADCs for recording. See Table 9 for possible values.

SR[2:0] Right Channel Source. The SR[2:0] bits select the right channel source to pass to the ADCs for recording. See Table 9 for possible values.

Default 0000h. This value selects the Mic input for both channels.

Sx2 - Sx0	Record Source
000	Mic
001	CD Input
010	Video Input
011	Aux Input
100	Line Input
101	Stereo Mix
110	Mono Mix
111	Phone Input

**Table 9. Input Mux Selection**



### 5.10 Record Gain Register (Index 1Ch)

D15	D14	D13	D12	D11	D10	D9	D8	D7	D6	D5	D4	D3	D2	D1	D0
Mute	0	0	0	GL3	GL2	GL1	GL0	0	0	0	0	GR3	GR2	GR1	GR0

- Mute** Record Gain Mute. Setting this bit mutes the input to the L/R ADCs.
- GL[3:0]** Left ADC Gain. The GL[3:0] bits control the input gain on the left channel of the analog source, applied after the input mux and before the ADCs. Each step corresponds to 1.5 dB gain adjustment, with 0000 = 0 dB. The total range is 0 dB to +22.5 dB gain. See Table 10 for further details.
- GR[3:0]** Right ADC Gain. The GR[3:0] bits control the input gain on the right channel of the analog source, applied after the input mux and before the ADCs. Each step corresponds to 1.5 dB gain adjustment, with 0000 = 0 dB. The total range is 0 dB to +22.5 dB gain. See Table 10 for further details.
- Default** 8000h. This value corresponds to 0 dB gain and Mute 'set'.

Gx3 - Gx0	Gain Level
1111	+22.5 dB
...	...
0001	+1.5 dB
0000	0 dB

**Table 10. Record Gain Values**

### 5.11 Record Gain Mic Register (Index 1Eh)

D15	D14	D13	D12	D11	D10	D9	D8	D7	D6	D5	D4	D3	D2	D1	D0
Mute	0	0	0	0	0	0	0	0	0	0	0	GM3	GM2	GM1	GM0

- Mute** Mic Record Gain Mute. When 'set', mutes the input to the microphone ADC.
- GM[3:0]** Mic ADC gain. The GM[3:0] bits control the input gain on the microphone source. The gain is applied after the input mux and before the ADC. Each step corresponds to 1.5 dB gain adjustment, with 0000 = 0 dB. The total range is 0 dB to +22.5 dB gain. See Table 10 for further details.
- Default** 8000h. This value corresponds to 0 dB gain and Mute 'set'.

### 5.12 General Purpose Register (Index 20h)

D15	D14	D13	D12	D11	D10	D9	D8	D7	D6	D5	D4	D3	D2	D1	D0
POP	ST	3D	LD	0	0	MIX	MS	LPBK	0	0	0	0	0	0	0

POP	PCM Out Path. When 'clear', the PCM out path is mixed pre 3D. When 'set', the PCM out path is mixed post 3D.
ST	Stereo Enhancement Enable. When 'set', the ST bit enables the simulated stereo enhancement via the SRS Mono algorithm.
3D	3D Enable. When 'set', the 3D bit enables the 3D stereo enhancement via the SRS Stereo algorithm.
LD	Loudness Enable. When 'set', the LD bit enables the loudness or "bass boost" via the equalizer algorithm.
MIX	Mono Output Path. This bit controls the source of the mono output driver. When 'clear', the output of the stereo-to-mono mixer is sent to the mono output. When 'set', the output of the microphone boost stage is sent to the mono output. The source of the stereo-to-mono mixer is controlled by the TMM bit in the <i>AC Mode Control Register (Index 5Eh)</i> . The source of the microphone boost stage is controlled by the MS bit in the <i>General Purpose Register (Index 20h)</i> .
MS	Microphone Select. The MS bit determines which of the two Mic inputs are passed to the mixer. When 'set', the MIC2 input is selected. When 'clear', the MIC1 input is selected.
LPBK	Loopback Enable. When 'set', the LPBK bit enables the ADC/DAC Loopback Mode. This bit routes the output of the ADCs to the input of the DACs without involving the AC-link.
Default	0000h

### 5.13 3D Control Register (Index 22h)

D15	D14	D13	D12	D11	D10	D9	D8	D7	D6	D5	D4	D3	D2	D1	D0
0	0	0	0	CR3	CR2	CR1	CR0	0	0	0	0	DP3	DP2	DP1	DP0

CR[3:0]	Center Control. The CR[3:0] bits control the amount of the sum signal, (L+R), that is added to the final left and right digital signals.
DP[3:0]	Depth Control. The DP[3:0] bits control the amount of processed difference signal, (L-R) <sub>p</sub> , that is added to the final left and right digital signals.
Default	0000h. This value corresponds to -22.5 dB center and depth attenuation.

This register is used to control the center and depth of the SRS stereo enhancement function in the effects engine. Each step corresponds to 1.5 dB gain adjustment, with a total available range from 0 dB to -22.5 dB attenuation. The recommended starting point for listening is -12 dB center attenuation and -4.5 dB depth attenuation, a register value of 070Ch.

### 5.14 Powerdown Control/Status Register (Index 26h)

D15	D14	D13	D12	D11	D10	D9	D8	D7	D6	D5	D4	D3	D2	D1	D0
EAPD	0	PR5	PR4	PR3	PR2	PR1	PR0	0	0	0	0	REF	ANL	DAC	ADC

EAPD	External Amplifier Power Down. The EAPD pin follows this bit and is generally used to power down external amplifiers. The EAPD bit is mutually exclusive with the SDSC bit in the <i>Serial Port Control Register (Index 6Ah)</i> . The SDSC bit must be 'clear' before the EAPD bit may be 'set'. If the SDSC bit is 'set', EAPD is a read-only bit and always returns '0'.
PR5	Internal Clock Disable. When 'set', the internal master clock is disabled (BIT_CLK running). The only way to recover from setting this bit is through a Cold Reset (driving the RESET# signal active).
PR4	AC-link Powerdown. When 'set', the AC-link is powered down (BIT_CLK off). The AC-link can be restarted through a Warm Reset using the SYNC signal, or a Cold Reset using the RESET# signal (primary audio codec only).
PR3	Analog Mixer Powerdown (Vref off). When 'set', the analog mixer and voltage reference are powered down. When clearing this bit, the ANL, ADC, and DAC bits should be checked before writing any mixer registers.
PR2	Analog Mixer Powerdown (Vref on). When 'set', the analog mixer is powered down (the voltage reference is still active). When clearing this bit, the ANL bit should be checked before writing any mixer registers.
PR1	Front DACs Powerdown. When 'set', the DACs are powered down. When clearing this bit, the DAC bit should be checked before sending any data to the DACs.
PR0	L/R ADCs and Input Mux Powerdown. When 'set', the ADCs and the ADC input muxes are powered down. When clearing this bit, no valid data will be sent down the AC-link until the ADC bit goes high.
REF	Voltage Reference Ready Status. When 'set', the REF bit indicates the voltage reference is at a nominal level.
ANL	Analog Ready Status. When 'set', the analog output mixer, input multiplexer, and volume controls are ready. When 'clear', no volume control registers should be written.
DAC	Front DAC Ready Status. When 'set', the DACs are ready to receive data across the AC-link. When 'clear', the DACs will not accept any valid data.
ADC	L/R ADCs Ready Status. When 'set', the ADCs are ready to send data across the AC-link. When 'clear', no data will be sent to the controller.
Default	0000h. This value indicates all blocks are powered on. The lower four bits will change as the CS4205 finishes an initialization and calibration sequence.

The PR[5:0] and the EAPD bits are powerdown control for different sections of the CS4205 as well as external amplifiers. The REF, ANL, DAC, and ADC bits are read-only status bits which, when 'set', indicate that a particular section of the CS4205 is ready. After the controller receives the Codec Ready bit in input Slot 0, these status bits must be checked before writing to any mixer registers. See Section 10, *Power Management*, for more information on the powerdown functions.

### 5.15 Extended Audio ID Register (Index 28h)

D15	D14	D13	D12	D11	D10	D9	D8	D7	D6	D5	D4	D3	D2	D1	D0
ID1	ID0	0	0	0	0	AMAP	0	0	0	0	0	VRM	0	0	VRA

- ID[1:0]**            Codec ID. These bits indicate the current codec configuration. When ID[1:0] = 00, the CS4205 is the primary audio codec. When ID[1:0] = 01, 10, or 11, the CS4205 is a secondary audio codec. The state of the ID[1:0] bits is determined at power-up from the ID[1:0]# pins and the current clocking scheme, see Table 27 on page 63.
- AMAP**            Audio Slot Mapping. The AMAP bit indicates whether the optional AC '97 2.1 compliant AC-link slot to audio DAC mapping is supported. This bit is a shadow of the AMAP bit in the *AC Mode Control Register (Index 5Eh)*. The PCM playback and capture slots are mapped according to Table 14 on page 43.
- VRM**            Variable Rate Mic Audio. The VRM bit indicates whether variable rate Mic audio is supported. This bit always returns '1', indicating that variable rate mic audio is available.
- VRA**            Variable Rate PCM Audio. The VRA bit indicates whether variable rate PCM audio is supported. This bit always returns '1', indicating that variable rate PCM audio is available.
- Default**            x209h. The *Extended Audio ID Register (Index 28h)* is a read-only register.

### 5.16 Extended Audio Status/Control Register (Index 2Ah)

D15	D14	D13	D12	D11	D10	D9	D8	D7	D6	D5	D4	D3	D2	D1	D0
0	PRL	0	0	0	0	MADC	0	0	0	0	0	VRM	0	0	VRA

PRL	Mic ADC Powerdown. When 'set', the PRL bit powers down the dedicated Mic ADC and corresponding input gain stage. To use the dedicated Mic ADC, clear the PRL bit first.
MADC	Mic ADC Ready Status. When 'set', the MADC bit indicates the dedicated Mic ADC is ready to transmit data.
VRM	Enable Variable Rate Mic Audio. When 'set', the VRM bit allows access to the <i>Mic ADC Rate Register (Index 34h)</i> . This bit must be 'set' in order to use variable mic capture rates. The VRM bit also serves as a powerdown for the Mic ADC SRC block. Clearing VRM will reset the <i>Mic ADC Rate Register (Index 34h)</i> to its default value and the SRC data path is flushed.
VRA	Enable Variable Rate Audio. When 'set', the VRA bit allows access to the <i>PCM Front DAC Rate Register (Index 2Ch)</i> and the <i>PCM L/R ADC Rate Register (Index 32h)</i> . This bit must be 'set' in order to use variable PCM playback or capture rates. The VRA bit also serves as a powerdown for the DAC and ADC SRC blocks. Clearing VRA will reset the <i>PCM Front DAC Rate Register (Index 2Ch)</i> and the <i>PCM L/R ADC Rate Register (Index 32h)</i> to their default values. The SRC data path is flushed and the Slot Request bits for the currently active DAC slots will be fixed at '0'.
Default	4000h

### 5.17 Audio Sample Rate Control Registers (Index 2Ch - 34h)

D15	D14	D13	D12	D11	D10	D9	D8	D7	D6	D5	D4	D3	D2	D1	D0
SR15	SR14	SR13	SR12	SR11	SR10	SR9	SR8	SR7	SR6	SR5	SR4	SR3	SR2	SR1	SR0

**SR[15:0]** Sample Rate Select. The *Audio Sample Rate Control Registers (Index 2Ch - 34h)* control playback and capture sample rates. The *PCM Front DAC Rate Register (Index 2Ch)* controls the Front Left and Front Right DAC sample rates. The *PCM L/R ADC Rate Register (Index 32h)* controls the Left and Right ADC sample rates. The *Mic ADC Rate Register (Index 34h)* controls the Microphone ADC sample rate. There are ten sample rates directly supported by this register, shown in Table 12. Any value written to this register not contained in Table 12 is not directly supported and will be decoded according to the ranges indicated in the table. The range boundaries have been chosen so that only bits SR[15:11] of each register will have to be considered. All register read transactions will reflect the actual value stored (column 2 in Table 12) and not the one attempted to be written.

**Default** BB80h. This value corresponds to 48 kHz sample rate.

Writes to the *PCM Front DAC Rate Register (Index 2Ch)* and the *PCM L/R ADC Rate Register (Index 32h)* are only available in Variable Rate PCM Audio mode when the VRA bit in the *Extended Audio Status/Control Register (Index 2Ah)* is 'set'. If VRA = 0, writes to the register are ignored and the register will always read BB80h. Writes to the *Mic ADC Rate Register (Index 34h)* are only available in Variable Rate Mic Audio mode when the VRM bit in the *Extended Audio Status/Control Register (Index 2Ah)* is 'set'. If VRM = 0, writes to the register are ignored and the register will always read BB80h. Table 11 lists the SRC registers and their corresponding SRC enable bit.

Register Index	SRC	SRC Enable Bit (Index 2Ah)
2Ch	PCM Front DAC Rate	VRA
32h	PCM L/R ADC Rate	VRA
34h	Mic ADC Rate	VRM

**Table 11. Audio Sample Rate Control Register Index**

Sample Rate (Hz)	SR[15:0], register content (hex value)	SR[15:0], decode range (hex value)	SR[15:11], decode range (bin value)
8,000	1F40	0000 - 1FFF	00000 - 00011
9,600	2580	2000 - 27FF	00100 - 00100
11,025	2B11	2800 - 2FFF	00101 - 00101
13,714	3592	3000 - 37FF	00110 - 00110
16,000	3E80	3800 - 47FF	00111 - 01000
22,050	5622	4800 - 57FF	01001 - 01010
24,000	5DC0	5800 - 6FFF	01011 - 01101
32,000	7D00	7000 - 8FFF	01110 - 10001
44,100	AC44	9000 - AFFF	10010 - 10101
48,000	BB80	B000 - FFFF	10110 - 11111

**Table 12. Directly Supported SRC Sample Rates for the CS4205**

### 5.18 Extended Modem ID Register (Index 3Ch)

D15	D14	D13	D12	D11	D10	D9	D8	D7	D6	D5	D4	D3	D2	D1	D0
ID1	ID0	0	0	0	0	0	0	0	0	0	0	0	0	0	0

**ID[1:0]** Codec ID. These bits indicate the current codec configuration. When ID[1:0] = 00, the CS4205 is the primary audio codec. When ID[1:0] = 01, 10, or 11, the CS4205 is a secondary audio codec. The state of the ID[1:0] bits is determined at power-up from the ID[1:0]# pins and the current clocking scheme, see Table 27 on page 63.

**Default** x000h. This value indicates no supported modem functions.

The *Extended Modem ID Register (Index 3Ch)* is a read/write register that identifies the CS4205 modem capabilities. Writing any value to this location issues a reset to modem registers (*Index 3Ch-54h*), including GPIO registers (*Index 4Ch - 54h*). Audio registers are not reset by a write to this location.

### 5.19 Extended Modem Status/Control Register (Index 3Eh)

D15	D14	D13	D12	D11	D10	D9	D8	D7	D6	D5	D4	D3	D2	D1	D0
0	0	0	0	0	0	0	PRA	0	0	0	0	0	0	0	GPIO

**PRA** GPIO Powerdown. When 'set', the PRA bit powers down the GPIO subsystem. When the GPIO section is powered down, all outputs must be tri-stated and input Slot 12 should be marked invalid when the AC-link is active. To use any GPIO functionality, including Internal Error Signaling, PRA must be cleared first.

**GPIO** GPIO. When 'set', the GPIO bit indicates the GPIO subsystem is ready for use. When 'set', input Slot 12 will also be marked valid.

**Default** 0100h

### 5.20 GPIO Pin Configuration Register (Index 4Ch)

D15	D14	D13	D12	D11	D10	D9	D8	D7	D6	D5	D4	D3	D2	D1	D0
0	0	0	0	0	0	0	0	0	0	0	GC4	GC3	GC2	GC1	GC0

**GC[4:0]** GPIO Pin Configuration. When 'set', the GC[4:0] bits define the corresponding GPIO pin as an input. When 'clear', the corresponding GPIO pin is defined as an output. When the SDEN bit in the *Serial Port Control Register (Index 6Ah)* is 'set', the GC[1:0] bits are read-only bits and always return '0'. When SDEN is 'clear', the GC[1:0] bits function normally. Likewise, GC2 depends on SDI1, GC3 depends on SDI2, and GC4 depends on SDI3. The SDI[1:3] bits are located in the *Serial Port Control Register (Index 6Ah)*.

**Default** 001Fh. This value corresponds to all GPIO pins configured as inputs.

After a Cold Reset or a modem Register Reset (see *Extended Modem ID Register (Index 3Ch)*), all GPIO pins are configured as inputs. The upper 11 bits of this register always return '0'.

### 5.21 GPIO Pin Polarity/Type Configuration Register (Index 4Eh)

D15	D14	D13	D12	D11	D10	D9	D8	D7	D6	D5	D4	D3	D2	D1	D0
1	1	1	1	1	1	1	1	1	1	1	GP4	GP3	GP2	GP1	GP0

**GP[4:0]** GPIO Pin Configuration. This register defines the GPIO input polarity (0 = Active Low, 1 = Active High) when a GPIO pin is configured as an input. The GP[4:0] bits define the GPIO output type (0 = CMOS, 1 = OPEN-DRAIN) when a GPIO pin is configured as an output. The GC[4:0] bits in the *GPIO Pin Configuration Register (Index 4Ch)* define the GPIO pins as inputs or outputs. See Table 13 for the various GPIO configurations.

Default FFFFh

After a Cold Reset or a modem Register Reset this register defaults to all 1's. The upper 11 bits of this register always return '1'.

GCx	GPx	Function	Configuration
0	0	Output	CMOS Drive
0	1	Output	Open Drain
1	0	Input	Active Low
1	1	Input	Active High (default)

**Table 13. GPIO Input/Output Configurations**

### 5.22 GPIO Pin Sticky Register (Index 50h)

D15	D14	D13	D12	D11	D10	D9	D8	D7	D6	D5	D4	D3	D2	D1	D0
0	0	0	0	0	0	0	0	0	0	0	GS4	GS3	GS2	GS1	GS0

**GS[4:0]** GPIO Pin Sticky. This register defines the GPIO input type (0 = not sticky, 1 = sticky) when a GPIO pin is configured as an input. The GPIO pin status of an input configured as "sticky" is 'cleared' by writing a '0' to the corresponding bit of the *GPIO Pin Status Register (Index 54h)*, and by reset.

Default 0000h

After a Cold Reset or a modem Register Reset this register defaults to all 0's, specifying "non-sticky". "Sticky" is defined as edge sensitive, "non-sticky" as level sensitive. The upper 11 bits of this register always return '0'.



### 5.23 GPIO Pin Wakeup Mask Register (Index 52h)

D15	D14	D13	D12	D11	D10	D9	D8	D7	D6	D5	D4	D3	D2	D1	D0
0	0	0	0	0	0	0	0	0	0	0	GW4	GW3	GW2	GW1	GW0

**GW[4:0]** GPIO Pin Wakeup. This register provides a mask for determining if an input GPIO change will generate a wakeup event (0 = no, 1 = yes). When the AC-link is powered up, a wakeup event will be communicated through the assertion of GPIO\_INT = 1 in input Slot 12. When the AC-link is powered down (*Powerdown Control/Status Register (Index 26h)* bit PR4 = 1 for primary codecs), a wakeup event will be communicated through a '0' to '1' transition on SDATA\_IN.

**Default** 0000h

GPIO bits which have been programmed as inputs, “sticky”, and “wakeup”, upon transition either (high-to-low) or (low-to-high) depending on pin polarity, will cause an AC-link wakeup if and only if the AC-link was powered down. Once the controller has re-established communication with the CS4205 following a Warm Reset, it will continue to signal the wakeup event through the GPIO\_INT bit of input Slot 12 until the AC '97 controller clears the interrupt-causing bit in the *GPIO Pin Status Register (Index 54h)*; or the “wakeup”, config, or “sticky” status of that GPIO pin changes.

After a Cold Reset or a modem Register Reset (see *Extended Modem ID Register (Index 3Ch)*) this register defaults to all 0's, specifying no wakeup event. The upper 11 bits of this register always return '0'.

### 5.24 GPIO Pin Status Register (Index 54h)

D15	D14	D13	D12	D11	D10	D9	D8	D7	D6	D5	D4	D3	D2	D1	D0
0	0	0	0	0	0	0	0	0	0	0	GI4	GI3	GI2	GI1	GI0

**GI[4:0]** GPIO Pin Status. This register reflects the state of all GPIO pin inputs and outputs. These values are also reflected in Slot 12 of every SDATA\_IN frame. GPIO inputs configured as “sticky” are ‘cleared’ by writing a '0' to the corresponding bit of this register. The GPIO\_INT bit in input Slot 12 is ‘cleared’ by clearing all interrupt-causing bits in this register.

**Default** 0000h

GPIO pins which have been programmed as inputs and “sticky”, upon transition either (high-to-low) or (low-to-high) depending on pin polarity, will cause the individual GI bit to be ‘set’, and remain ‘set’ until ‘cleared’. GPIO pins which have been programmed as outputs are controlled either through output Slot 12 or through this register, depending on the state of the GPOC bit in the *Misc. Crystal Control Register (Index 60h)*. If the GPOC bit is ‘cleared’, the GI bits in this register are read-only and reflect the status of the corresponding GPIO output pin ‘set’ through output slot 12. If the GPOC bit is ‘set’, the GI bits in this register are read/write bits and control the corresponding GPIO output pins.

The default value is always the state of the GPIO pin. The upper 11 bits of this register should be forced to zero in this register and input Slot 12.

### 5.25 AC Mode Control Register (Index 5Eh)

D15	D14	D13	D12	D11	D10	D9	D8	D7	D6	D5	D4	D3	D2	D1	D0
DACS	CAPS1	CAPS0	MICS	0	0	TMM	DDM	AMAP	0	SM1	SM0	SDOS1	SDOS0	SPDS1	SPDS0

**DACS** DAC Source Select. The DACS bit controls the source of data routed to the DACs. If this bit is ‘clear’, the DACs will receive data from the DAC slots, see Table 14 for actual slots used. If this bit is ‘set’, the DACs will receive data from the CS4205 digital effects engine.

---

CAPS[1:0]	L/R Capture Source Select. The CAPS[1:0] bits control the source of data routed to the L/R ADC slots, see Table 14 for actual slots used. Table 15 lists the available capture options. If a reserved source is selected, the capture slot data will be fixed to '0'.
MICS	Microphone Capture Source Select. The MICS bit selects the source of data routed to the Mic ADC slot. If this bit is 'clear', the Mic capture slot will receive data from the Mic ADC. If this bit is 'set', the Mic capture slot will receive the left channel data from the first serial data input port.
TMM	True Mono Mode. The TMM bit controls the source of the stereo-to-mono mixer that feeds into the mono out select mux. If this bit is 'clear', the output of the stereo input mixer is sent to the stereo-to-mono mixer. If this bit is 'set', the output of the DAC direct mode mux is sent to the stereo-to-mono mixer. This allows a true mono mix that includes the PC Beep and Phone inputs and also works during DAC direct mode.
DDM	DAC Direct Mode. The DDM bit controls the source of the line output drivers. When this bit is 'clear', the CS4205 stereo output mixer drives the line output. When this bit is 'set', the CS4205 audio DACs (DAC1 and DAC2) directly drive the line output.
AMAP	Audio Slot Mapping. The AMAP bit controls whether the CS4205 responds to the Codec ID based slot mapping as outlined in the AC '97 2.1 Specification. This bit is shadowed in the <i>Extended Audio ID Register (Index 28h)</i> . Refer to Table 14 for the slot mapping configurations.
SM[1:0]	Slot Map. The SM[1:0] bits define the Slot Mapping for the CS4205 when the AMAP bit is 'cleared'. Refer to Table 14 for the slot mapping configurations.
SDOS[1:0]	Serial Data Output Source Select. The SDOS[1:0] bits control the source of data routed to the CS4205 first serial data output port. Table 15 on page 43 lists the available source options. If a reserved source is selected, the serial output data will be fixed to '0'.
SPDS[1:0]	S/PDIF Transmitter Source Select. The SPDS[1:0] bits control the source of data routed to the S/PDIF transmitter. Table 15 on page 43 lists the available source options.
Default	0080h

See Section 3, *Digital Signal Paths*, for more information on using the bits in this register to create various digital signal path options.

Slot Assignment Mode	Codec ID		Slot Map		AMAP	Slot Assignments								
	ID1	ID0	SM1	SM0		DAC		SDOUT		SDO2		ADC		
						SPDIF for SPDS = 00				SPDIF for SPDS = 01				
						L	R	L	R	L	R	L	R	M
AMAP Mode 0	0	0	X	X	1	3	4	7	8	6	9	3	4	6
AMAP Mode 1	0	1	X	X	1	3	4	7	8	6	9	3	4	6
AMAP Mode 2	1	0	X	X	1	7	8	6	9	10	11	7	8	6
AMAP Mode 3	1	1	X	X	1	6	9	7	8	10	11	7	8	6
Slot Map Mode 0	X	X	0	0	0	3	4	7	8	6	9	3	4	6
Slot Map Mode 1	X	X	0	1	0	7	8	6	9	10	11	7	8	6
Slot Map Mode 2	X	X	1	0	0	6	9	7	8	10	11	7	8	6
Slot Map Mode 3	X	X	1	1	0	5	11	7	8	6	9	5	11	6

**Table 14. Slot Mapping for the CS4205**

CAPS[1:0], SDOS[1:0], or SPDS[1:0]	L/R Capture Source (CAPS[1:0])	Serial Data Output Source (SDOS[1:0])	S/PDIF Transmitter Source (SPDS[1:0])
00	L/R ADCs	SDOUT slots	DAC slots
01	reserved	reserved	SDO2 slots
10	Digital Mixer	Digital Mixer	Digital Mixer
11	Digital Effects	Digital Effects	Digital Effects

**Table 15. Digital Signal Source Selects**

### 5.26 Misc. Crystal Control Register (Index 60h)

D15	D14	D13	D12	D11	D10	D9	D8	D7	D6	D5	D4	D3	D2	D1	D0
0	0	Res	DPC	0	0	Reserved	10dB	CRST	Reserved	GPOC	Reserved	Reserved	Reserved	Reserved	LOSM

DPC	DAC Phase Control. This bit controls the phase of the PCM stream sent to the DACs (after SRC). When 'cleared' the phase of the signal will remain unchanged. When this bit is 'set', each PCM sample will be inverted before being sent to the DACs.
10dB	Microphone 10 dB Boost. When 'set', the 10dB bit enables an additional boost of 10 dB on the selected microphone input. In combination with the 20dB boost bit in the <i>Microphone Volume Register (Index 0Eh)</i> this bit allows for variable boost from 0 dB to +30 dB in steps of 10 dB.
CRST	Force Cold Reset. The CRST bit is used as an override to the New Warm Reset behavior defined during PR4 powerdown. If this bit is 'set', an active RESET# signal will force a Cold Reset to the CS4205 during a PR4 powerdown.
GPOC	General Purpose Output Control. The GPOC bit specifies the mechanism by which the status of a General Purpose Output pin can be controlled. If this bit is 'cleared', the GPO status is controlled through the standard AC '97 method of setting the appropriate bits in output Slot 12. If this bit is 'set', the GPO status is controlled through the <i>GPIO Pin Status Register (Index 54h)</i> .
LOSM	Loss of SYNC Mute Enable. The LOSM bit controls the loss of SYNC mute function. If this bit is 'set', the CS4205 will mute all analog outputs for the duration of loss of SYNC. If this bit is 'cleared', the mixer will continue to function normally during loss of SYNC. The CS4205 expects to sample SYNC 'high' for 16 consecutive BIT_CLK periods and then 'low' for 240 consecutive BIT_CLK periods, otherwise loss of SYNC becomes true.
Default	0003h

### 5.27 S/PDIF Control Register (Index 68h)

D15	D14	D13	D12	D11	D10	D9	D8	D7	D6	D5	D4	D3	D2	D1	D0
SPEN	Val	0	Fs	L	CC6	CC5	CC4	CC3	CC2	CC1	CC0	Emph	Copy	/Audio	Pro

SPEN	S/PDIF Enable. The SPEN bit enables S/PDIF data transmission on the SPDO/SDO2 pin. The SPEN bit routes the left and right channel data from the AC '97 controller, the digital mixer, or the digital effects engine to the S/PDIF transmitter block. The actual data routed to the S/PDIF block are controlled through the SPDS[1:0]/AMAP/SM[1:0] configuration in the <i>AC Mode Control Register (Index 5Eh)</i> . This bit can only be 'set' if the SDO2 bit in the <i>Serial Port Control Register (Index 6Ah)</i> is '0'. If the SDO2 bit is 'set', SPEN is a read-only bit and always returns '0'.
Val	Validity. The Val bit is mapped to the V bit (bit 28) of every <i>sub-frame</i> . If this bit is 'clear', the signal is suitable for conversion or processing.
Fs	Sample Rate. The Fs bit indicates the sampling rate for the S/PDIF data. The inverse of this bit is mapped to bit 25 of the channel status block. When the Fs bit is 'clear', the sampling frequency is 48 kHz. When 'set', the sampling frequency is 44.1 kHz. The actual rate at which S/PDIF data are being transmitted solely depends on the master clock frequency of the CS4205. The Fs bit is merely an indicator to the S/PDIF receiver.
L	Generation Status. The L bit is mapped to bit 15 of the channel status block. For category codes 001xxxx, 0111xxx and 100xxxx, a value of '0' indicates original material and a value of '1' indicates a copy of original material. For all other category codes the definition of the L bit is reversed.
CC[6:0]	Category Code. The CC[6:0] bits are mapped to bits 8-14 of the channel status block.
Emph	Data Emphasis. The Emph bit is mapped to bit 3 of the channel status block. When 'set', 50/15 $\mu$ s filter pre-emphasis is indicated. When is 'clear', no pre-emphasis is indicated.
Copy	Copyright. The Copy bit is mapped to bit 2 of the channel status block. If the Copy bit is 'set' copyright is not asserted and copying is permitted.
/Audio	Audio / Non-Audio. The /Audio bit is mapped to bit 1 of the channel status block. If the /Audio bit is 'clear', the data transmitted over S/PDIF is assumed to be digital audio. If the /Audio bit is 'set', non-audio data is assumed.
Pro	Professional/Consumer. The Pro bit is mapped to bit 0 of the channel status block. If the Pro bit is 'clear', consumer use of the audio control block is indicated. If the bit is 'set', professional use is indicated.
Default	0000h

For a further discussion of the proper use of the channel status bits see application note *AN22: Overview of Digital Audio Interface Data Structures* [3].

### 5.28 Serial Port Control Register (Index 6Ah)

D15	D14	D13	D12	D11	D10	D9	D8	D7	D6	D5	D4	D3	D2	D1	D0
SDEN	0	0	0	0	0	0	0	0	SDI3	SDI2	SDI1	SDO2	SDSC	SDF1	SDF0

- SDEN** Serial Data Output Enable. The SDEN bit enables transmission of serial data on the SDOOUT pin. The SDEN bit routes the left and right channel data from the AC '97 controller, the digital mixer, or the digital effects engine to the serial data port. The actual data routed to the serial data port are controlled through the SDOS[1:0]/AMAP/SM[1:0] configuration in the *AC Mode Control Register (Index 5Eh)*. SDEN also functions as a master control for the serial data input ports, the second serial data output port and the serial clock. Setting this bit also disables the GPIO[1:0] pins and clears the GC[1:0] bits in the *GPIO Pin Configuration Register (Index 4Ch)*. Clearing this bit re-enables the GPIO[1:0] pins and sets the GC[1:0] bits.
- SDI[3:1]** Serial Data Input Enable. The SDI[3:1] bits individually enable the reception of serial data on the SDI[3:1] pins. Each of these bits routes the left and right channel data from the corresponding serial data input port to its associated volume control. These bits can only be set if the SDEN bit is '1' and will be cleared automatically if SDEN returns to '0'. If the SDEN bit is '0', SDI[3:1] are read-only bits and always return '0'. If allowed, setting one of these bits also disables the corresponding GPIO pin and clears the associated GC bit for this pin in the *GPIO Pin Configuration Register (Index 4Ch)*. Clearing one of these bits re-enables the corresponding GPIO pin and sets the associated GC bit.
- SDO2** Serial Data Output 2 Enable. The SDO2 bit enables transmission of serial data on the SPDO/SDO2 pin. The SDO2 bit routes the left and right channel data from the AC '97 controller to the second serial data port. The actual slots routed to the second serial data port are controlled through the AMAP/SM[1:0] configuration in the *AC Mode Control Register (Index 5Eh)*. This bit can only be 'set' if the SDEN bit is '1' and will be 'cleared' automatically if SDEN returns to '0'. Furthermore, the SDO2 bit can only be 'set' if the SPEN bit in the *S/PDIF Control Register (Index 68h)* is '0'. If the SDEN bit is '0' or the SPEN bit is '1', SDO2 is a read-only bit and always returns '0'.
- SDSC** Serial Clock Enable. The SDSC bit enables transmission of a serial clock on the EAPD/SCLK pin. Serial data can be routed to DACs that support internal SCLK mode without transmitting a serial clock. For DACs that only support external SCLK mode, transmission of a serial clock is required and this bit must be set to '1'. This bit can only be set if the SDEN bit is '1' and will be cleared automatically if SDEN returns to '0'. Furthermore, the SDSC bit can only be 'set' if the EAPD bit in the *Powerdown Control/Status Register (Index 26h)* is '0'. If the SDEN bit is '0' or the EAPD bit is '1', SDSC is a read-only bit and always returns '0'.
- SDF[1:0]** Serial Data Format. The SDF[1:0] bits control the format of the serial data transmitted on the two output ports and the three input ports. All ports will use the same format. See Table 16 for available formats.
- Default** 0000h

SDF1	SDF0	Serial Data Format
0	0	I <sup>2</sup> S
0	1	Left Justified
1	0	Right Justified, 20-bit data
1	1	Right Justified, 16-bit data

**Table 16. Serial Data Format Selection**

### 5.29 Special Feature Address Register (Index 6Ch)

D15	D14	D13	D12	D11	D10	D9	D8	D7	D6	D5	D4	D3	D2	D1	D0
0	0	0	0	0	0	0	0	0	0	0	0	A3	A2	A1	A0

A[3:0] Special Feature Address. This register functions as an index register to select the desired functionality of the *Special Feature Data Register (Index 6Eh)*. Before using any of these indexed registers, the correct index value must be written to bits A[3:0].

Default 0000h

### 5.30 Special Feature Data Register (Index 6Eh)

D15	D14	D13	D12	D11	D10	D9	D8	D7	D6	D5	D4	D3	D2	D1	D0
D15	D14	D13	D12	D11	D10	D9	D8	D7	D6	D5	D4	D3	D2	D1	D0

D[15:0] Special Feature Data. This register is an indexed data port for the special feature registers (Index 6E, Address 00h - 0Fh) which control advanced subsystems of the CS4205, such as digital mixer settings, effects engine parameters, ZV Port control, and internal error condition signaling. Before using any of these functions, the correct index value must be written to the *Special Feature Address Register (Index 6Ch)*.

Default 8000h

### 5.31 Digital Mixer Input Volume Registers (Index 6Eh, Address 00h - 05h)

D15	D14	D13	D12	D11	D10	D9	D8	D7	D6	D5	D4	D3	D2	D1	D0
Mute	0	GL5	GL4	GL3	GL2	GL1	GL0	0	0	GR5	GR4	GR3	GR2	GR1	GR0

Mute Digital Mixer Mute. Setting this bit mutes the respective input signal, both left and right inputs.

GL[5:0] Left Volume Control. The GL[5:0] bits are used to control the digital mixer left channel input volume. Each step corresponds to 1 dB gain adjustment. The total range is 0 dB to -63 dB gain.

GR[5:0] Right Volume Control. The GR[4:0] bits are used to control the digital mixer right channel input volume. Each step corresponds to 1 dB gain adjustment. The total range is 0 dB to -63 dB gain.

Default 8000h. This value corresponds to 0 dB gain and Mute 'set'.

If the digital mixer signals an overflow condition by setting the MLOF or MROF bit in the *IEC Status Register (Index 6Eh, Address 0Bh)*, the controller should correct the error by reducing the digital mixer input volumes in these registers. The Digital Mixer Input Volume Registers are listed in Table 17.

Register Address	Function
00h	PCM Input Volume
01h	ADC Input Volume
02h	SDI1 Volume
03h	SDI2 Volume
04h	SDI3 Volume
05h	ZV Volume

**Table 17. Digital Mixer Input Volume Register Index**

### 5.32 Serial Data Port Volume Control Registers (Index 6Eh, Address 06h - 07h)

D15	D14	D13	D12	D11	D10	D9	D8	D7	D6	D5	D4	D3	D2	D1	D0
Mute	0	GL5	GL4	GL3	GL2	GL1	GL0	0	0	GR5	GR4	GR3	GR2	GR1	GR0

- Mute                      Serial Data Port Mute. Setting this bit mutes the respective input signal, both left and right inputs.
- GL[5:0]                 Left Volume Control. The GL[5:0] bits are used to control the serial data port left channel output volume. Each step corresponds to 1 dB gain adjustment. The total range is 0 dB to -63 dB gain.
- GR[5:0]                 Right Volume Control. The GR[5:0] bits are used to control the serial data port right channel output volume. Each step corresponds to 1 dB gain adjustment. The total range is 0 dB to -63 dB gain.
- Default                 8000h. This value corresponds to 0 dB gain and Mute 'set'.

The Serial Data Port Volume Control Registers are listed in Table 18.

Register Address	Function
06h	SDOUT Volume
07h	SDO2 Volume

**Table 18. Serial Port Volume Control Register Index**



### 5.33 Signal Processing Engine Control Register (Index 6Eh, Address 08h)

D15	D14	D13	D12	D11	D10	D9	D8	D7	D6	D5	D4	D3	D2	D1	D0
Res	SDI1M	SRZC1	SRZC0	LPFS1	LPFS0	HPFS1	HPFS0	GL3	GL2	GL1	GL0	GR3	GR2	GR1	GR0

SDI1M	Serial Data Input 1 Mode. The SDI1M bit controls the flow of data from the first serial data input into the signal processing engine. If this bit is '0', the two channels of the SDI1 port are routed to their respective channels of the SDI1 volume control. If this bit is '1', the left channel of the SDI1 port is routed to both, the left and right channels of the SDI1 volume control.
SRZC[1:0]	Soft Ramp and Zero Cross Control. The SRZC bits control when changes take effect on the digital volume controls. Table 19 lists the available settings.
LPFS[1:0]	Low Pass Filter Select. The LPFS[1:0] bits select the center frequency of the low pass filter for the EQ algorithm. Table 19 lists the available settings.
HPFS[1:0]	High Pass Filter Select. The HPFS[1:0] bits select the center frequency of the high pass filter for the EQ algorithm. Table 19 lists the available settings.
GL[3:0]	Effects Engine Left Output Volume. The GL[3:0] bits are used to control the effects engine left channel output volume. Each step corresponds to 1 dB gain adjustment, with 0000 = 0 dB attenuation. The total range is 0 dB to -15 dB attenuation.
GR[3:0]	Effects Engine Right Output Volume. The GR[3:0] bits are used to control the effects engine right channel output volume. Each step corresponds to 1 dB gain adjustment, with 0000 = 0 dB attenuation. The total range is 0 dB to -15 dB attenuation.
Default	1800h

If the digital effects engine signals an overflow condition by setting the ELOF or EROF bit in the *IEC Status Register* (Index 6Eh, Address 0B), the controller should correct the error by reducing the effects engine output volume in this register.

SRZC[1:0] LPFS[1:0] HPFS[1:0]	Volume Change Mode	Low Pass Filter	High Pass Filter
00	immediately	20 Hz	10 kHz
01	on zero crossings	50 Hz	15 kHz
10	soft ramp (1/8 dB step per frame)	100 Hz	20 kHz
11	1/8 dB step per zero crossing	reserved	reserved

**Table 19. Volume Change Modes and EQ Filter Selects**

### 5.34 Internal Error Condition Control/Status Registers (Index 6Eh, Address 09h - 0Bh)

D15	D14	D13	D12	D11	D10	D9	D8	D7	D6	D5	D4	D3	D2	D1	D0
EROF	ELOF	MROF	MLOF	0	AMOR	AROR	ALOR	0	0	0	0	0	0	0	0

EROF Effects Engine Right Channel Overflow

ELOF Effects Engine Left Channel Overflow

MROF Digital Mixer Right Channel Overflow

MLOF Digital Mixer Left Channel Overflow

AMOR Mic ADC Overrange

AROR L/R ADC Right Channel Overrange

ALOR L/R ADC Left Channel Overrange

Default 0000h

The *IEC Config Register (Index 6Eh, Address 09h)* enables error signaling for each potential error source. If a bit is 'clear', the corresponding source will not be monitored for errors. If a bit is 'set', the corresponding source will be monitored and is able to signal an error condition. If an error occurs, the corresponding bit in the *IEC Status Register (Index 6Eh, Address 0Bh)* will be 'set' and remains 'set' until the error is cleared, even if the error condition is no longer present. This behavior is equivalent to "sticky" (edge sensitive) GPIO input pins.

The *IEC Wakeup Register (Index 6Eh, Address 0Ah)* provides a mask for determining if an IEC will generate a wake-up or GPIO\_INT. If a bit is '0', the corresponding error condition will not generate an interrupt. If a bit is 'set', the corresponding error condition will generate an interrupt. For details about wakeup interrupts refer to the *GPIO Pin Wakeup Mask Register (Index 52h)*.

The *IEC Status Register (Index 6Eh, Address 0Bh)* reflects the state of all internal error conditions. If a bit is 'clear', the corresponding source has not encountered an error condition or is not being monitored for errors. If a bit is 'set', the corresponding source has encountered an error condition. The IEC bit in input slot 12 is a logic OR of all bits in this register. An error condition is cleared by writing a '0' to the corresponding bit of this register. Before clearing an error condition, the controller should correct the error to prevent repeated error signaling. Table 20 lists all the internal error sources and corrective measures for each source.

IEC Bit	Error Source	Correction Method
ALOR	L/R ADC left channel overrange	GL[3:0] bits in reg 1Ch
AROR	L/R ADC right channel overrange	GR[3:0] bits in reg 1Ch
AMOR	Mic ADC overrange	GM[3:0] bits in reg 1Eh
MLOF	Digital mixer left channel overflow	GL[5:0] bits in reg 6Eh, addr 00h-05h
MROF	Digital mixer right channel overflow	GR[5:0] bits in reg 6Eh, addr 00h-05h
ELOF	Effects engine left channel overflow	GL[3:0] bits in reg 6Eh, addr 08h
EROF	Effects engine right channel overflow	GR[3:0] bits in reg 6Eh, addr 08h

**Table 20. Internal Error Sources and Correction Methods**

### 5.35 BIOS-Driver Interface Control Registers (Index 6Eh, Address 0Ch - 0Dh)

<b>D15</b>	<b>D14</b>	<b>D13</b>	<b>D12</b>	<b>D11</b>	<b>D10</b>	<b>D9</b>	<b>D8</b>	<b>D7</b>	<b>D6</b>	<b>D5</b>	<b>D4</b>	<b>D3</b>	<b>D2</b>	<b>D1</b>	<b>D0</b>
E15	E14	E13	E12	E11	E10	E9	E8	E7	E6	E5	E4	E3	E2	E1	E0

E[15:0] Event Configuration. The E[15:0] bits control the BIOS-Driver Interface mechanism.

Default 0000h

The *BDI Config Register (Index 6Eh, Address 0Ch)* enables BIOS-Driver communication for each possible event. If a bit is '0', the corresponding event will not be communicated. If a bit is '1', the corresponding event will be communicated by asserting the BDI bit in input slot 12. If an event occurs, the BIOS will 'set' the corresponding bit in the *BDI Status Register (Index 7Ah)*. This bit remains 'set' until it is cleared by the driver, acknowledging the event has been handled. This behavior is equivalent to "non-sticky" (level sensitive) GPIO input pins.

The *BDI Wakeup Register (Index 6Eh, Address 0Dh)* provides a mask for determining if a BDI event will generate a wakeup or GPIO\_INT. If a bit is '0', the corresponding event will not generate an interrupt. If a bit is '1', the corresponding event will generate an interrupt. Refer to the *GPIO Pin Wakeup Mask Register (Index 52h)* for details about wakeup interrupts.

### 5.36 ZV Port Control/Status Registers (Index 6Eh, Address 0Eh - 0Fh)

<b>D15</b>	<b>D14</b>	<b>D13</b>	<b>D12</b>	<b>D11</b>	<b>D10</b>	<b>D9</b>	<b>D8</b>	<b>D7</b>	<b>D6</b>	<b>D5</b>	<b>D4</b>	<b>D3</b>	<b>D2</b>	<b>D1</b>	<b>D0</b>
ZVEN	LOCK	0	Ph24	Ph23	Ph22	Ph21	Ph20	Ph19	Ph18	Ph17	Ph16	Ph15	Ph14	Ph13	Ph12
Reserved				Ph11	Ph10	Ph9	Ph8	Ph7	Ph6	Ph5	Ph4	Ph3	Ph2	Ph1	Ph0

ZVEN ZV Port Input Enable. The ZVEN bit enables the reception of asynchronous serial data on the ZLRCLK, ZSDATA, and ZSCLK pins. The ZVEN bit routes the left and right channel data from the ZV Port to the asynchronous SRC (ASRC) and on to the ZV volume control. This bit also functions as a powerdown control for the ASRC. When this bit is 'cleared', the ASRC is powered down. To use the ZV Port and the ASRC, this bit must be 'set'.

LOCK ZV Port Locked. When 'set', the LOCK read-only bit indicates the ZV Port is receiving valid data and the receiver has locked on to the data stream. If this bit is 'cleared', no valid data are received on the ZV Port and the ZV input to the digital mixer will be muted.

Ph[24:0] Phase Increment. The Ph[24:0] bits contain the current Phase Increment used by the ASRC. The current sample rate can be determined by  $F_{s_{in}} = F_{s_{out}} * Ph/16,777,216$ , where  $F_{s_{out}}$  is 48 kHz. For more information on how to use these bits see Section 7, *ZV Port*.

Default 0000h

Register Address	Function
0Eh	ZV Port Control/Stat 1
0Fh	ZV Port Control/Stat 2

**Table 21. ZV Port Control/Status Register Index**

### 5.37 BIOS-Driver Interface Status Register (Index 7Ah)

<b>D15</b>	<b>D14</b>	<b>D13</b>	<b>D12</b>	<b>D11</b>	<b>D10</b>	<b>D9</b>	<b>D8</b>	<b>D7</b>	<b>D6</b>	<b>D5</b>	<b>D4</b>	<b>D3</b>	<b>D2</b>	<b>D1</b>	<b>D0</b>
E15	E14	E13	E12	E11	E10	E9	E8	E7	E6	E5	E4	E3	E2	E1	E0

E[15:0] Event Status. This register, in conjunction with the *BIOS-Driver Interface Control Registers (Index 6Eh, Address 0Ch - 0Dh)*, controls the BIOS-Driver Interface mechanism.

---

Default                    0000h

The *BDI Status Register (Index 7Ah)* reflects the state of all possible events. If a bit is '0', the corresponding event has not occurred or has already been handled by the driver. If a bit is '1', the corresponding event has occurred and has not been handled by the driver yet. The BDI bit in input slot 12 is a logic OR of all bits in this register ANDed with their corresponding bit in the *BDI Config Register (Index 6Eh, Address 0Ch)*. After handling an event, the driver should clear it by writing a '0' to the corresponding bit of this register.

**5.38 Vendor ID1 Register (Index 7Ch)**

<b>D15</b>	<b>D14</b>	<b>D13</b>	<b>D12</b>	<b>D11</b>	<b>D10</b>	<b>D9</b>	<b>D8</b>	<b>D7</b>	<b>D6</b>	<b>D5</b>	<b>D4</b>	<b>D3</b>	<b>D2</b>	<b>D1</b>	<b>D0</b>
F7	F6	F5	F4	F3	F2	F1	F0	S7	S6	S5	S4	S3	S2	S1	S0

- F[7:0] First Character of Vendor ID. With a value of F[7:0] = 43h, these bits define the ASCII 'C' character.
- S[7:0] Second Character of Vendor ID. With a value of S[7:0] = 52h, these bits define the ASCII 'R' character.
- Default 4352h. This register contains read-only data.

**5.39 Vendor ID2 Register (Index 7Eh)**

<b>D15</b>	<b>D14</b>	<b>D13</b>	<b>D12</b>	<b>D11</b>	<b>D10</b>	<b>D9</b>	<b>D8</b>	<b>D7</b>	<b>D6</b>	<b>D5</b>	<b>D4</b>	<b>D3</b>	<b>D2</b>	<b>D1</b>	<b>D0</b>
T7	T6	T5	T4	T3	T2	T1	T0	0	DID2	DID1	DID0	1	REV2	REV1	REV0

- T[7:0] Third Character of Vendor ID. With a value of T[7:0] = 59h, these bits define the ASCII 'Y' character.
- DID[2:0] Device ID. With a value of DID[2:0] = 101, these bits specify the audio codec is a CS4205.
- REV[2:0] Revision. With a value of REV[2:0] = 001, these bits specify the audio codec revision is 'A'.
- Default 595xh. This register contains read-only data.

The two Vendor ID registers provide a means to determine the manufacturer of the AC '97 audio codec. The first three bytes of the Vendor ID registers contain the ASCII code for the first three letters of Crystal (CRY). The final byte of the Vendor ID registers is divided into a Device ID field and a Revision field. Table 22 lists the currently defined Device ID's.

<b>DID2 - DID0</b>	<b>Part Name</b>
000	CS4297
001	CS4297A
010	CS4294/CS4298
011	CS4299
100	CS4201
101	CS4205
110	CS4291
111	CS4202

**Table 22. Device ID with Corresponding Part Number**

## 6. SERIAL DATA PORTS

### 6.1 Overview

The CS4205 implements two serial data output ports and three serial data input ports that can be used for digital docking or multi-channel expansion. Each serial port consists of 4 signals: MCLK, SCLK, LRCLK, and SDATA. The existing 256 Fs BIT\_CLK will be used as MCLK. The clock pins are shared between all the serial ports with only the SDATA pins being separate; SDOOUT for the first output port, SDO2 for the second output port, and SDI[3:1] for the three input ports. Serial data is received and transmitted on these ports every AC-link frame.

The serial data port is controlled by the SDEN, SDSC, SDI[3:1], and SDO2 bits in the *Serial Port Control Register (Index 6Ah)*. All the serial data port pins are multiplexed with other functions and cannot be used unless the other function is disabled or powered down; see Section 9, *Exclusive Functions*. Some audio DACs can run in an internal SCLK mode where SCLK is internally derived from MCLK and LRCLK. In this case, SCLK generation in the CS4205 is optional.

A feature has been designed into the CS4205 that allows the phase of the internal DACs to be re-

versed. This DAC phase reversal is controlled by the DPC bit in the *Misc. Crystal Control Register (Index 60h)*. This feature is necessary since the phase response for external DACs is unknown and the phase response of the internal DACs can vary depending on the path determined by the DDM bit in the *AC Mode Control Register (Index 5Eh)*. This feature guarantees that all DACs in a system have the same phase response, maintaining the accuracy of spatial cues.

In the CS4205, the volume of the serial port data is controlled with the *Serial Data Port Volume Control Registers (Index 6Eh, Address 06h - 07h)*. However, there is no SRC available on this data, so it is the responsibility of the controller or host software to provide this functionality if desired.

### 6.2 Multi-Channel Expansion

For multi-channel expansion, the two serial data output ports are used to send AC-link data to one or two external stereo DACs to support up to a total of six channels. The first serial port takes the digital audio data from the SDOOUT slots. The second serial port takes the digital audio data from the SDO2 slots. See Table 14 on page 43 for the actual slots used depending on configuration. Figure 15 shows a six channel application using the CS4205.

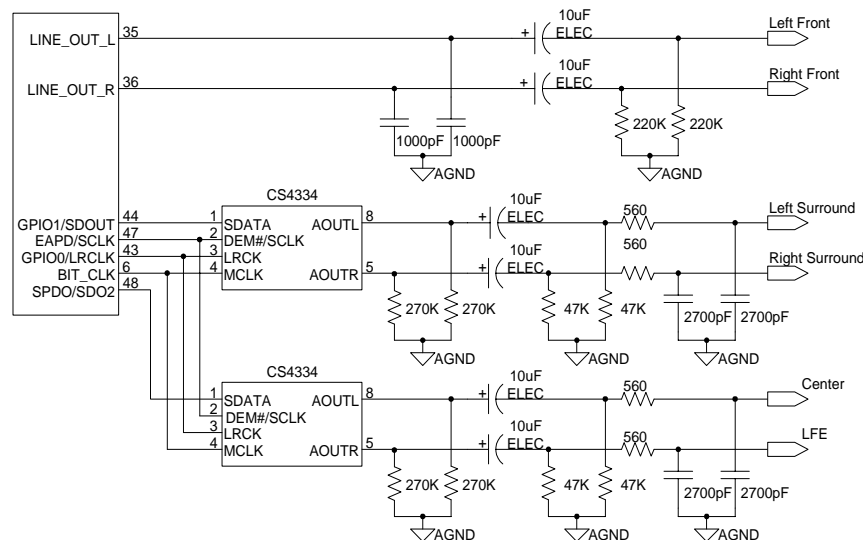

**Figure 15. Serial Data Port: Six Channel Circuit**

### 6.3 Digital Docking

The CS4205 features three serial data input ports used to receive data from three stereo ADCs inside a docking station. One serial data output port is used to transmit data to a stereo DAC inside the docking station. To fully utilize digital docking, the CS4205 should be configured for digital centric mode; see Section 3.2, *Digital Centric Mode*. This will allow the docking sources to be mixed with the analog sources from the notebook. The resulting mix is available for listening on both the notebook and the docking station and for capturing on the host. Figure 16 shows a block diagram for digital docking applications of the CS4205.

Note the BIT\_CLK output should be buffered before sending it as MCLK to the docking station converters. The capacitance loading of the docking station connector, the relatively long trace, and the multiple loads on this signal may exceed the load-

ing restrictions on BIT\_CLK. Buffering of SCLK and LRCLK should also be considered.

### 6.4 Serial Data Formats

In order to support a wide variety of serial audio DACs and ADCs, the CS4205 can transmit and receive serial data in four different formats. The desired format is selected through the SDF[1:0] bits in the *Serial Port Control Register (Index 6Ah)*. All serial ports use the same serial data format when enabled. In all cases, LRCLK will be synchronous with Fs, and SCLK will be 64 Fs (BIT\_CLK/4). Serial data is transitioned by the CS4205 on the falling edge of SCLK and latched by the DACs on the next rising edge. Serial data is shifted out MSB first in all supported formats, but LRCLK polarity as well as data justification, alignment, and resolution vary. Table 23 shows the principal characteristics of each serial format.

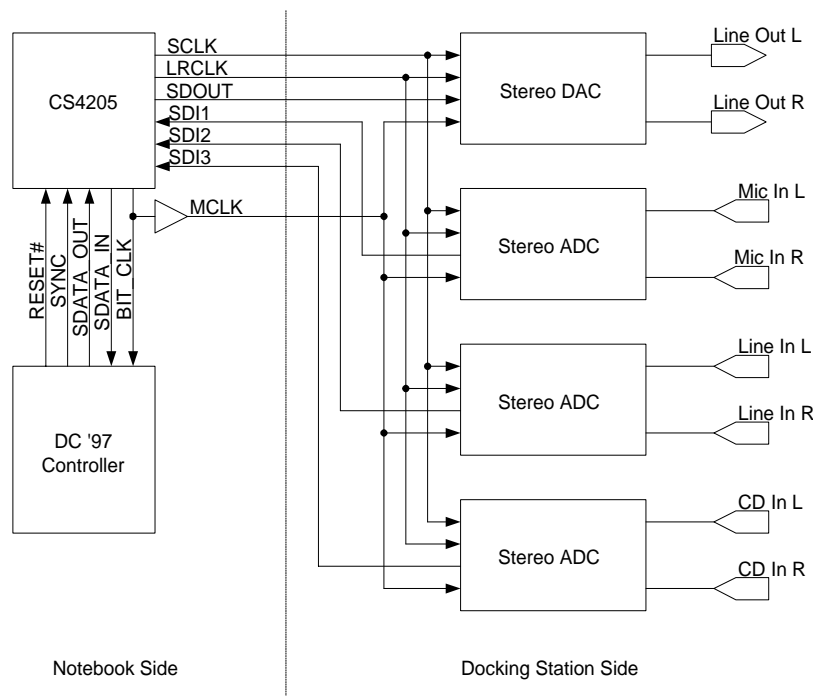

**Figure 16. Digital Docking Connection Diagram**

SDF[1:0]	LRCLK Polarity	Data Justification	Data Alignment (MSB vs. LRCLK)	Data Resolution	Timing Diagram	Recommended DAC/ADC
0 0	negative	left justified	1 SCLK delayed	20-bit	Figure 17	CS4334/CS5331A
0 1	positive	left justified	not delayed	20-bit	Figure 18	CS4335/CS5330A
1 0	positive	right justified	not delayed	20-bit	Figure 19	CS4337/none
1 1	positive	right justified	not delayed	16-bit	Figure 20	CS4338/none

**Table 23. Serial Data Formats and Compatible DACs/ADC's for the CS4205**

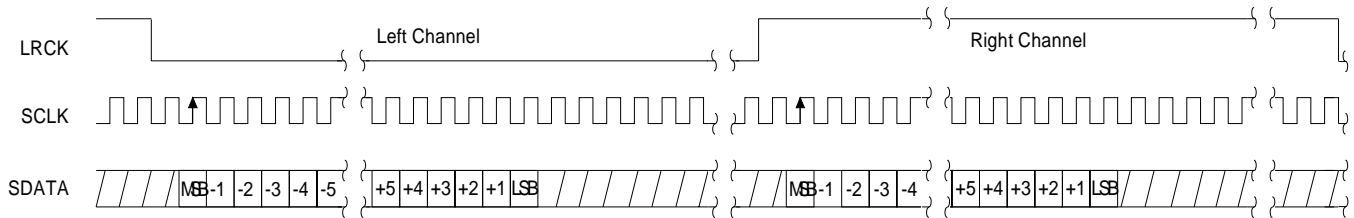

**Figure 17. Serial Data Format 0 (I<sup>2</sup>S)**

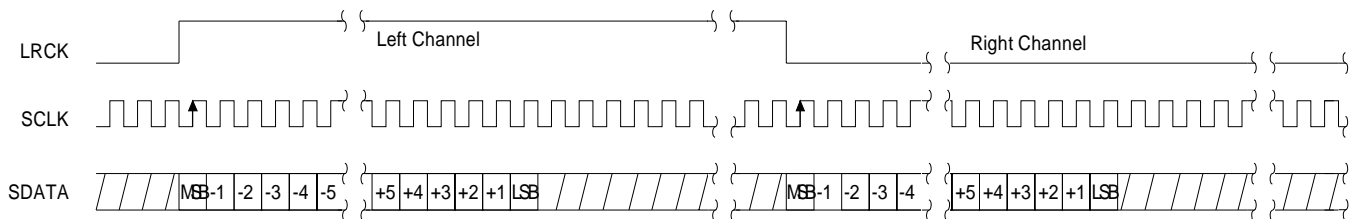

**Figure 18. Serial Data Format 1 (Left Justified)**

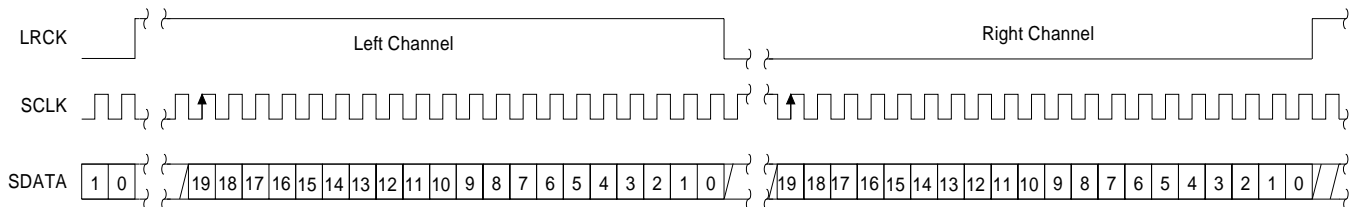

**Figure 19. Serial Data Format 2 (Right Justified, 20-bit data)**

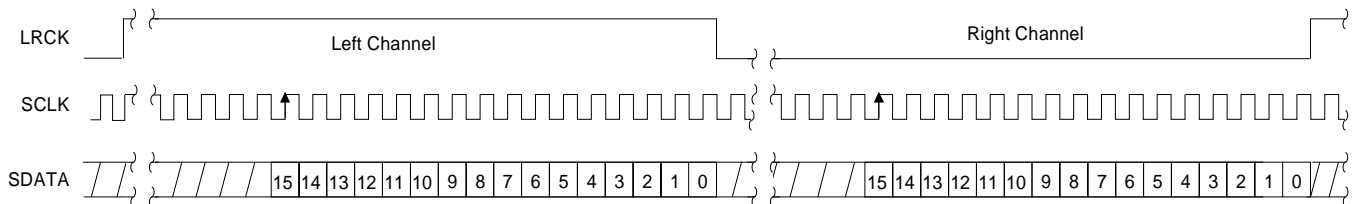

**Figure 20. Serial Data Format 3 (Right Justified, 16-bit data)**



## 7. ZV PORT

The CS4205 implements an asynchronous serial data input port that conforms to the Zoomed Video Port (ZV Port) specification. ZV Port data is asynchronous I<sup>2</sup>S data in PCM format with 16 bits of resolution. The ZV Port interface consists of four signals: MCLK, SCLK, LRCLK, and SDATA. However, the CS4205 does not require a connection to the asynchronous MCLK. The other three signals are respectively received on ZSCLK, ZLRLCK, and ZSDATA. Although the ZV Port specification calls for SCLK running at 32 Fs, the CS4205 supports any SCLK from 32 Fs up to 128 Fs. In all cases, only the first 16 bits of each channel will be recovered from the incoming serial data stream. Figure 21 shows the ZV Port format. The ZV Port is controlled by the ZVEN, LOCK, and Ph[24:0] bits in the *ZV Port Control/Status Registers (Index 6Eh, Address 0Eh - 0Fh)*.

Since the data received on the ZV Port is asynchronous and at varying sample rates, it must be sample rate converted before being sent to the digital mixer. The asynchronous SRC is similar in function to

the synchronous DAC SRC, but differs in the way samples are received and how the sample rate is determined. While the synchronous SRC is being programmed to the desired sample rate by the host and requests samples from the host at the programmed rate, the asynchronous SRC receives data from a push source at an unknown rate. Therefore, the asynchronous SRC must determine the rate of incoming data and calculate the necessary parameters. The current sample rate can be determined from the Ph[24:0] bits in the *ZV Port Control/Status Registers (Index 6Eh, Address 0Eh - 0Fh)* by  $F_{S_{in}} = F_{S_{out}} * Ph / 16,777,216$ , where  $F_{S_{out}}$  is 48 kHz. Once the rate estimator has settled, the LOCK bit will be asserted. If the incoming clock rate changes, LOCK will be de-asserted until the rate estimator has settled again. Settling may take up to 400 ms. As long as the receiver is unlocked, the ZV input to the digital mixer will be muted, regardless of the state of the ZV mute bit in the *Digital Mixer Input Volume Register (Index 6E, Address 00h - 05h)*.

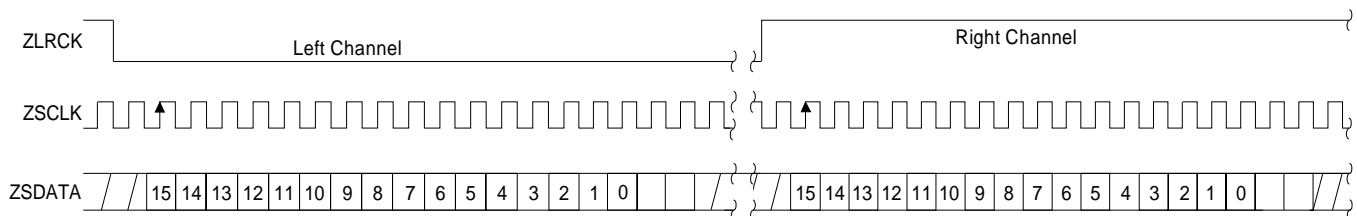

**Figure 21. ZV Port Format (I<sup>2</sup>S, 16-bit data)**

## 8. SONY/PHILIPS DIGITAL INTERFACE (S/PDIF)

The S/PDIF digital output is used to interface the CS4205 to consumer audio equipment external to the PC. This output provides an interface for storing digital audio data or playing digital audio data to digital speakers. Figure 22 illustrates the circuits necessary for implementing the IEC-958 optical or consumer interface. For further information on S/PDIF operation see application note *AN22: Overview of Digital Audio Interface Data Structures* [3]. For further information on S/PDIF recommended transformers see application note *AN134: AES and S/PDIF Recommended Transformers* [4].

## 9. EXCLUSIVE FUNCTIONS

Some of the digital pins on the CS4205 have multiplexed functionality. These functions are mutually exclusive and cannot be requested at the same time. The following pairs of functions are mutually exclusive:

- GPIO and Serial Data Port (GPIO0 pin is shared with LRCLK pin, GPIO1 pin is shared with SDOOUT pin, and GPIO[4:2] pins are shared with SDI[3:1] pins)

- EAPD and Serial Data Port Serial Clock (EAPD pin is shared with SCLK pin)
- S/PDIF and Second Serial Data Port (SPDO pin is shared with SDO2 pin)

Use of the GPIO0/LRCLK, GPIO1/SDOUT, and GPIO[4:2]/SDI[3:1] pins for serial data port has priority over their GPIO functionality. There is no priority assigned to the other two exclusive functions. A function currently in use must be disabled or powered down before the corresponding exclusive function can be enabled. The following control bits for these functions will behave differently than normal bits: the EAPD bit in the *Powerdown Control/Status Register (Index 26h)*, the GC[4:0] bits in the *GPIO Pin Configuration Register (Index 4Ch)*, the SPEN bit in the *S/PDIF Control Register (Index 68h)*, and the SDI[3:1], SDO2, and SDSC bits in the *Serial Port Control Register (Index 6Ah)*. These bits can become read-only bits if they control a feature that is currently unavailable because the corresponding exclusive feature is already in use, or the corresponding master control for this feature is not set.

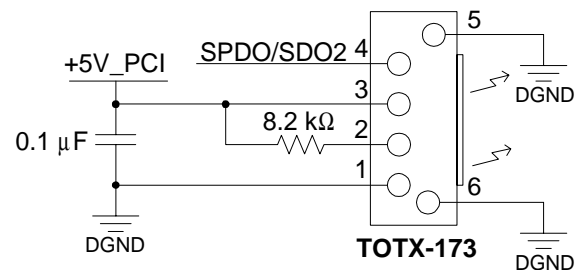
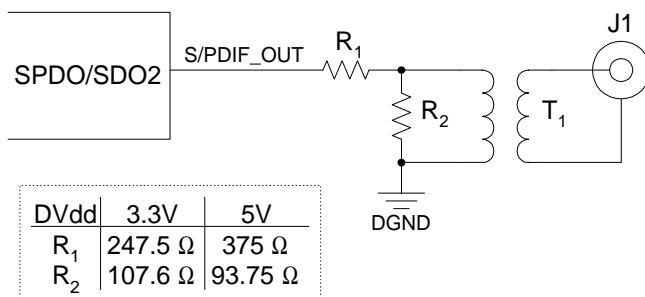

Figure 22. S/PDIF Output

## 10. POWER MANAGEMENT

### 10.1 AC '97 Reset Modes

The CS4205 supports four reset methods, as defined in the AC '97 Specification: *Cold Reset*, *Warm Reset*, *New Warm Reset*, and *Register Reset*. A Cold Reset results in all AC '97 logic (registers included) initialized to its default state. A Warm Reset or New Warm Reset leaves the contents of the AC '97 register set unaltered. A Register Reset initializes only the AC '97 registers to their default states.

#### 10.1.1 Cold Reset

A Cold Reset is achieved by asserting RESET# for a minimum of 1  $\mu$ s after the power supply rails have stabilized. This is done in accordance with the minimum timing specifications in the *AC '97 Serial Port Timing* section on page 10. Once de-asserted, all of the CS4205 registers will be reset to their default power-on states and the BIT\_CLK and SDATA\_IN signals will be reactivated.

#### 10.1.2 Warm Reset

A Warm Reset allows the AC-link to be reactivated without losing information in the CS4205 registers. A Warm Reset is required to resume from a D3<sub>hot</sub> state where the AC-link had been halted yet full power had been maintained. A primary codec Warm Reset is initiated when the SYNC signal is driven high for at least 1  $\mu$ s and then driven low in the absence of the BIT\_CLK clock signal. The BIT\_CLK clock will not restart until at least 2 nor-

mal BIT\_CLK clock periods (162.8 ns) after the SYNC signal is de-asserted. A Warm Reset of the secondary codec is recognized when the primary codec on the AC-link resumes BIT\_CLK generation. The CS4205 will wait for BIT\_CLK to be stable to restore SDATA\_IN activity, S/PDIF and/or serial data port transmission on the following frame.

#### 10.1.3 New Warm Reset

The New Warm Reset also allows the AC-link to be reactivated without losing information in the registers. A New Warm Reset is required to resume from a D3<sub>cold</sub> state where AC-link power has been removed. New Warm Reset is recognized by the low-high transition of RESET# after the AC-link has been programmed into PR4 powerdown. The New Warm Reset functionality can be disabled by setting the CRST bit in the *Misc. Crystal Control Register (Index 60h)*.

#### 10.1.4 Register Reset

The last reset mode provides a Register Reset to the CS4205. This is available only when the CS4205 AC-link is active and the Codec Ready bit is 'set'. The audio (including extended audio) control registers (Index 00h - 3Ah) and the vendor specific registers (Index 5Ah - 7Ah) are reset to their default states by a write of any value to the Reset Register (Index 00h). The modem (including GPIO) registers (*Index 3Ch - 56h*) are reset to their default states by a write of any value to the *Extended Modem ID Register (Index 3Ch)*.

## 10.2 Powerdown Controls

The *Powerdown Control/Status Register (Index 26h)* controls the power management functions. The PR[5:0] bits in this register control the internal powerdown states of the CS4205. Powerdown control is available for individual subsections of the CS4205 by asserting any PRx bit or any combination of PRx bits. All powerdown states except PR4 and PR5 can be resumed by clearing the corresponding PRx bit. Table 24 shows the mapping of the power control bits to the functions they manage.

When PR0 is ‘set’, the L/R ADCs and the Input Mux are shut down and the ADC bit in the *Powerdown Control/Status Register (Index 26h)* is ‘cleared’ indicating the ADCs are no longer in a ready state. The same is true for PR1 and the DACs, PR2 and the analog mixer, and PR3 and the voltage reference (Vrefout). When one of these bits is ‘cleared’, the corresponding subsystem will begin a power-on process, and the associated status bit will be ‘set’ when the hardware is ready.

In a primary codec the PR4 bit powers down the AC-link, but all other analog and digital sub-

systems continue to function. The required resume sequence from a PR4 state is either a Warm Reset or a New Warm Reset, depending on whether a D3<sub>hot</sub> or D3<sub>cold</sub> state has been entered.

The PR5 bit disables all internal clocks and powers down the DACs and the ADCs, but maintains operation of the BIT\_CLK and the analog mixer. A Cold Reset is the only way to restore operation to the CS4205 after asserting PR5. To achieve a complete digital powerdown, PR4 and PR5 must be asserted within a single AC output frame. This will also drive BIT\_CLK ‘low’.

The CS4205 does not automatically mute any input or output when the powerdown bits are ‘set’. The software driver controlling the AC ’97 device must manage muting the input and output analog signals before putting the part into any power management state. The definition of each PRx bit may affect a single subsection or a combination of subsections within the CS4205. Table 25 contains the matrix of subsections affected by the respective PRx function. Table 26 shows the different operating power consumption levels for different powerdown functions.

PR Bit	Function
PR0	L/R ADCs and Input Mux Powerdown
PR1	Front DACs Powerdown
PR2	Analog Mixer Powerdown (Vref on)
PR3	Analog Mixer Powerdown (Vref off)
PR4	AC-link Powerdown (BIT_CLK off)*
PR5	Internal Clock Disable

\* Applies only to primary codec

**Table 24. Powerdown PR Bit Functions**

PR Bit	ADCs	DACs	Mixer	Analog Reference	AC Link	Internal Clock Off	Mic ADC
PR0	•						
PR1		•					
PR2	•	•	•				•
PR3	•	•	•	•			•
PR4					•		
PR5	•	•				•	•
PRL							•

**Table 25. Powerdown PR Function Matrix for the CS4205**

Power State	I <sub>DVdd1</sub> (mA) [DVdd=3.3 V]	I <sub>DVdd1</sub> (mA) [DVdd=5 V]	I <sub>AVdd1</sub> (mA)
Full Power + SRC's	TBD	TBD	TBD
Full Power + S/PDIF <sup>1</sup>	TBD	TBD	TBD
Full Power	TBD	TBD	TBD
ADCs off (PR0)	TBD	TBD	TBD
DACs off (PR1)	TBD	TBD	TBD
Audio off (PR2)	TBD	TBD	TBD
Vref off (PR3)	TBD	TBD	TBD
AC-Link off (PR4)	TBD	TBD	TBD
Internal Clocks off (PR5)	TBD	TBD	TBD
Digital off (PR4+PR5)	TBD	TBD	TBD
All off (PR3+PR4+PR5)	TBD	TBD	TBD
RESET	TBD	TBD	TBD

**Table 26. Power Consumption by Powerdown Mode for the CS4205**

<sup>1</sup> Assuming standard resistive load for transformer coupled coaxial S/PDIF output (R<sub>load</sub> = 292 Ohm, DVdd = 3.3 V) (R<sub>load</sub> = 415 Ohm, DVdd = 5 V). General: I<sub>DVdd S/PDIF</sub> = I<sub>DVdd</sub> + DVdd/R<sub>load</sub>/2

## 11. CLOCKING

The CS4205 may be operated as a primary or secondary codec. As a primary codec, the system clock for the AC-link may be generated from an external 24.576 MHz clock source, a 24.576 MHz crystal, or the internal Phase Locked Loop (PLL). The PLL allows the CS4205 to accept external clock frequencies other than 24.576 MHz. As a secondary codec, the system clock is derived from BIT\_CLK, which is generated by the primary codec. The CS4205 uses the presence or absence of a valid clock on the XTL\_IN pin in conjunction with the state of the ID[1:0]# pins to determine the clocking configuration. See Table 27 for all available CS4205 clocking modes.

### 11.1 PLL Operation (External Clock)

The PLL mode is activated if a valid clock is present on XTL\_IN before the rising edge of RESET#. Once PLL mode is entered, the XTL\_OUT pin is redefined as the PLL loop filter, as shown in Figure 23. The ID[1:0]# inputs determine the configuration of the internal divider ratios required to generate the 12.288 MHz BIT\_CLK output; see Table 27 on page 63 for additional details. In PLL mode, the CS4205 is configured as a primary codec independent of the state of the ID[1:0]# pins. If 24.576 MHz is chosen as the external clock input (ID[1:0]# inputs both pulled high or left floating), the PLL is disabled and the clock is used directly. The loop filter is not required and XTL\_OUT is left unconnected. For all other clock input choices, the loop filter is required. The ID[1:0] bits of the *Extended Audio ID Register* (Index 28h) and the *Extended Modem ID Register* (Index 3Ch) will always report '00' in PLL mode.

### 11.2 24.576 MHz Crystal Operation

If a valid clock is not present on XTL\_IN during the rising edge of RESET#, the device disables the PLL input and latches the state of the ID[1:0]# inputs. If the ID[1:0]# inputs are both pulled high or left floating, the device is configured as a primary codec. An external 24.576 MHz crystal is used as the system clock as shown in Figure 24.

### 11.3 Secondary Codec Operation

If a valid clock is not present on XTL\_IN and either ID[1:0]# input is pulled low during the rising edge of RESET#, the device is determined to be a secondary codec. The BIT\_CLK pin is configured as an input and the CS4205 is driven from the 12.288 MHz BIT\_CLK of the primary codec. The ID[1:0] bits of the *Extended Audio ID Register* (Index 28h) and the *Extended Modem ID Register* (Index 3Ch) will report the state of the ID[1:0]# inputs.

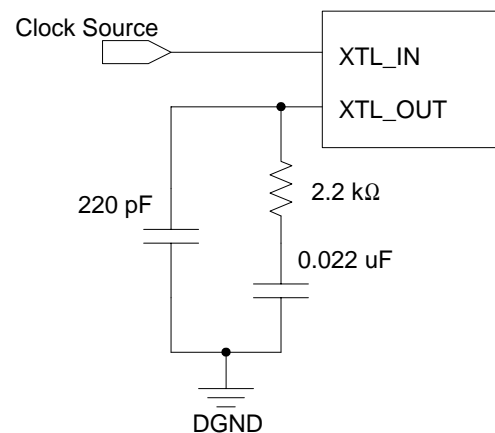

**Figure 23. PLL External Loop Filter**

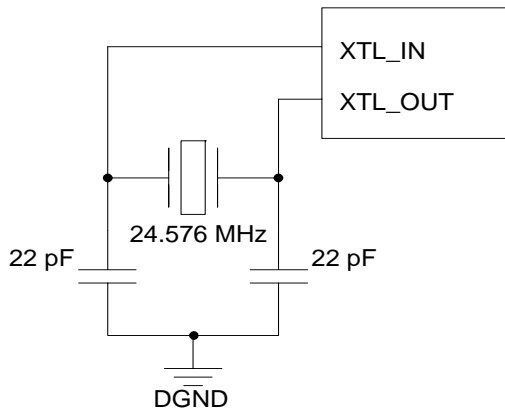
**Figure 24. External Crystal**

External Clock on XTL_IN	ID1#	ID0#	AC-Link Timing Mode	Codec ID	Clock Source	Clock Rate (MHz)	PLL Active	Application Notes
Yes	1	1	Primary	0	External	24.576	No	clock generator driving XTL_IN
Yes	1	0	Primary	0	External	14.31818	Yes	external clock source driving XTL_IN loop filter connected to XTL_OUT
Yes	0	1	Primary	0	External	27.000	Yes	
Yes	0	0	Primary	0	External	48.000	Yes	
No	1	1	Primary	0	XTAL	24.576	No	crystal connected to XTL_IN, XTL_OUT
No	1	0	Secondary	1	BIT_CLK	12.288	No	BIT_CLK from primary codec driving BIT_CLK on all secondary codecs
No	0	1	Secondary	2	BIT_CLK	12.288	No	
No	0	0	Secondary	3	BIT_CLK	12.288	No	

**Table 27. Clocking Configurations for the CS4205**

## 12. ANALOG HARDWARE DESCRIPTION

The analog input section consists of four stereo line-level inputs (LINE\_L/R, CD\_L/GND/R, VIDEO\_L/R, and AUX\_L/R), two selectable mono microphone inputs (MIC1 and MIC2), and two mono inputs (PC\_BEEP and PHONE). The analog output section consists of a mono output (MONO\_OUT) and a stereo line-level output (LINE\_OUT\_L/R). This section describes the analog hardware needed to interface with these pins. The designs presented in this section are compliant with Chapter 17 of Microsoft's® *PC 99 System Design Guide* [7] (referred to as PC 99) and Chapter 11 of Microsoft's® *PC 2001 System Design Guide* [8] (referred to as PC 2001). For information on EMI reduction techniques refer to the application note *AN165: CS4297A/CS4299 EMI Reduction Techniques* [5].

### 12.1 Analog Inputs

All analog inputs to the CS4205, including CD\_GND, should be capacitively coupled to the input pins. Unused analog inputs should be tied together and connected through a capacitor to analog ground or tied to the Vrefout pin directly. The maximum allowed voltage for analog inputs, except the microphone input, is 1 V<sub>RMS</sub>. The maximum allowed voltage for the microphone input depends on the selected boost setting.

#### 12.1.1 Line Inputs

Figure 25 shows circuitry for a line-level stereo input. Replicate this circuit for the Video and Aux inputs. This design attenuates the input by 6 dB, bringing the signal from the PC 99 specified 2 V<sub>RMS</sub>, to the CS4205 maximum allowed 1 V<sub>RMS</sub>.

#### 12.1.2 CD Input

The CD line-level input has an extra pin, CD\_GND, providing a pseudo-differential input for both CD\_L and CD\_R. This pin takes the

common-mode noise out of the CD inputs when connected to the CD analog source ground. Following the reference designs in Figure 26 and Figure 27 provides extra attenuation of common mode noise coming from the CD-ROM drive, thereby producing a higher quality signal. One percent resistors are recommended since closely matched resistor values provide better common-mode attenuation of unwanted signals. The circuit shown in Figure 26 can be used to attenuate a 2 V<sub>RMS</sub> CD input signal by 6 dB. The circuit shown in Figure 27 can be used for a 1 V<sub>RMS</sub> CD input signal.

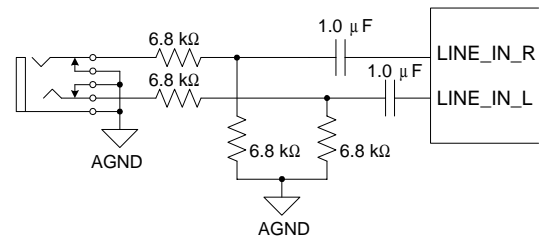

**Figure 25. Line Input (Replicate for Video and AUX)**

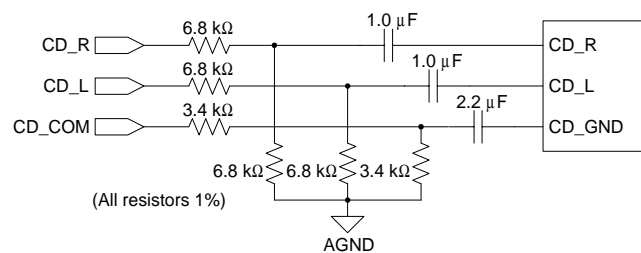

**Figure 26. Differential 2 V<sub>RMS</sub> CD Input**

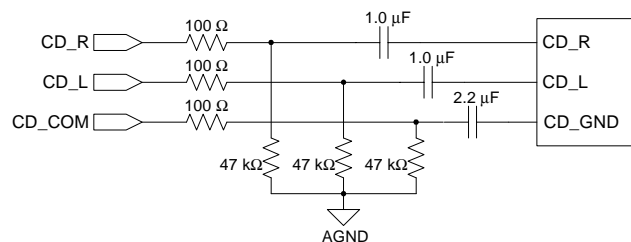

**Figure 27. Differential 1 V<sub>RMS</sub> CD Input**



### 12.1.3 Microphone Inputs

Figure 28 illustrates an input circuit suitable for dynamic and electret microphones. Electret, also known as phantom-powered, microphones use the right channel (ring) of the jack for power. The design also supports the recommended advanced frequency response for voice recognition as specified in PC 99 and PC 2001. The microphone input of the CS4205 has an integrated pre-amplifier. Using combinations of the 10dB bit in the *Misc. Crystal Control Register (Index 60)* and the 20dB bit in the *Mic Volume Register (Index 0Eh)* the pre-amplifier gain can be set to 0 dB, 10 dB, 20 dB, or 30 dB.

### 12.1.4 PC BEEP Input

The PC\_BEEP input is useful for mixing the output of the “beeper” (timer chip), provided in most PCs, with the other audio signals. When the CS4205 is held in reset, PC\_BEEP is passed directly to the line output. This allows the system sounds or “beeps” to be available before the AC '97 interface has been activated. Figure 29 illustrates a typical input circuit for the PC\_BEEP input. If PC\_BEEP is driven from a CMOS gate, the 4.7 kΩ resistor should be tied to analog ground instead of +5VA. Although this input is described for a low-quality “beeper”, it is of the same high-quality as all other analog inputs and may be used for other purposes.

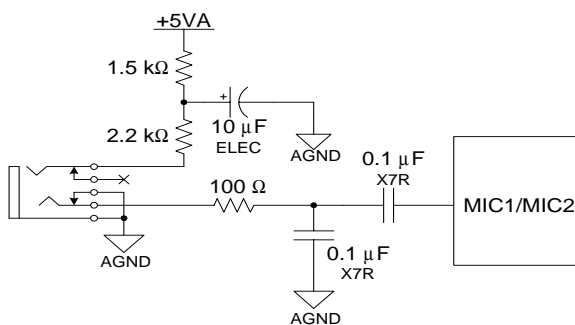

**Figure 28. Microphone Input**

### 12.1.5 Phone Input

One application of the PHONE input is to interface to the output of a modem analog front end (AFE) device so that modem dialing signals and protocol negotiations may be monitored through the audio system. Figure 30 shows a design for a modem connection where the output is fed from the CS4205 MONO\_OUT pin through a divider. The divider ratio shown does not attenuate the signal, providing an output voltage of 1 V<sub>RMS</sub>. If a lower output voltage is desired, the resistors can be replaced with appropriate values, as long as the total load on the output is kept greater than 10 kΩ. The PHONE input is divided by 6 dB to accommodate a line-level source of 2 V<sub>RMS</sub>.

## 12.2 Analog Outputs

The analog output section provides a stereo and a mono output. The MONO\_OUT, LINE\_OUT\_L, and LINE\_OUT\_R pins require 680 pF to 1000 pF NPO dielectric capacitors between the corresponding pin and analog ground. Each analog output is DC-biased up to the Vrefout voltage signal refer-

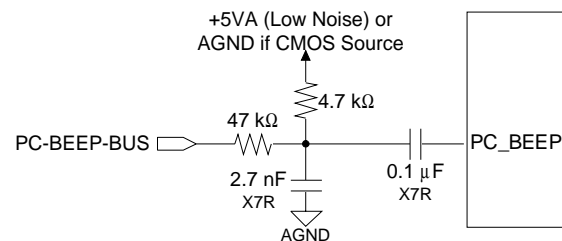

**Figure 29. PC\_BEEP Input**

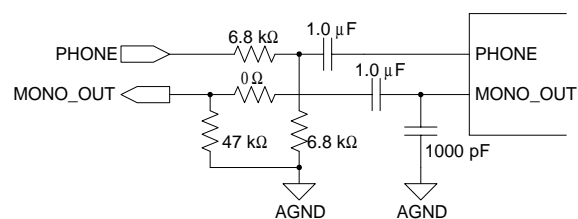

**Figure 30. Modem Connection**

ence, nominally 2.4 V. This requires the outputs be AC-coupled to external circuitry (AC loads must be greater than 10 k $\Omega$  for the line output).

### 12.2.1 Stereo Output

See Figure 31 for a stereo line-level output reference design.

### 12.2.2 Mono Output

The mono output, MONO\_OUT, can be either a sum of the left and right output channels, attenuated by 6 dB to prevent clipping at full scale, or the selected Mic signal. The mono out channel can drive the PC internal mono speaker using an appropriate buffer circuit.

## 12.3 Miscellaneous Analog Signals

The AFLT1, AFLT2, and AFLT3 pins must have a 1000 pF NPO capacitor to analog ground. These capacitors provide a single-pole low-pass filter at the inputs to the ADCs. This makes low-pass filters at each analog input pin unnecessary.

The REFFLT pin must have a short, wide trace to a 2.2  $\mu$ F and a 0.1  $\mu$ F capacitor connected to analog ground (see Figure 33 in Section 13, *Grounding and Layout*, for an example). The 2.2  $\mu$ F capacitor must not be replaced by any other value (it may be replaced with two 1  $\mu$ F capacitors in parallel) and must be ceramic with low leakage current. Electrolytic capacitors should not be used. No other connection should be made, as any coupling onto this pin will degrade the analog performance of the CS4205. Likewise, digital signals should be kept away from REFFLT for similar reasons.

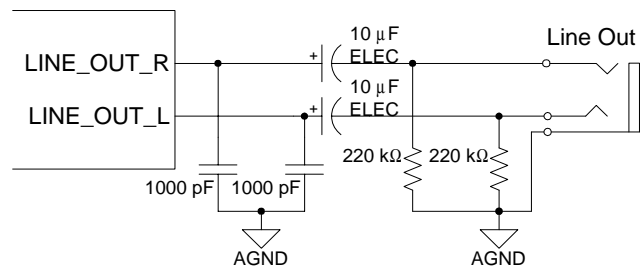
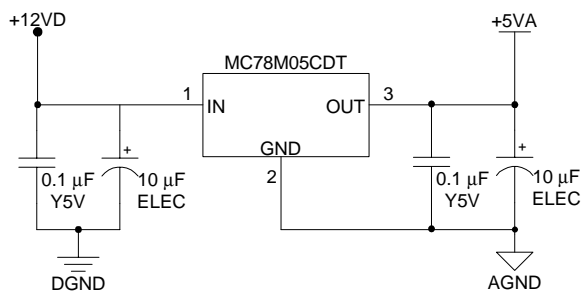

**Figure 31. Stereo Output**

## 12.4 Power Supplies

The power supplies providing analog power should be as clean as possible to minimize coupling into the analog section which could degrade analog performance. The +5 V analog supply should be generated from a voltage regulator (7805 type) connected to a +12 V supply. This helps isolate the analog circuitry from noise typically found on +5 V digital supplies. A typical voltage regulator circuit for analog power using an MC78M05CDT is shown in Figure 32. The AVdd1/AVss1 analog power/ground pin pair on the CS4205 supplies power to all the analog circuitry and should be connected to +5 VA/AGND. The AVdd2 and AVss2 pins are not used on the CS4205 and may be left floating or tied to +5 VA/AGND for backwards compatibility.

The DVdd2/DVss2 digital power/ground pin pair on the CS4205 should be connected to the same digital supply as the controller's AC-link interface. Since the digital interface on the CS4205 may operate at either +3.3 V or +5 V, proper connection of these pins will depend on the digital power supply of the controller. The DVdd1/DVss1 pair supplies power to the clocking circuitry and needs to be connected to the +5 VA/AGND power supply when the CS4205 is in PLL clocking mode. In XTAL or OSC clocking modes these pins may be connected to either +5 VA/AGND or use the same power supply used for DVdd2/DVss2.



**Figure 32. +5V Analog Voltage Regulator**

## **12.5 Reference Design**

See Section 16 for a CS4205 reference design.

### 13. GROUNDING AND LAYOUT

Figure 33 on page 69 shows the conceptual layout for the CS4205 in XTAL or OSC clocking modes. The decoupling capacitors should be located physically as close to the pins as possible. Also, note the connection of the REFFLT decoupling capacitors to the ground return trace connected directly to the ground return pin, AVss1.

It is strongly recommended that separate analog and digital ground planes be used. Separate ground planes keep digital noise and return currents from modulating the CS4205 ground potential and degrading performance. The digital ground pins should be connected to the digital ground plane and kept separate from the analog ground connections of the CS4205 and any other external analog circuitry. All analog components and traces should be located over the analog ground plane and all digital components and traces should be located over the digital ground plane.

The common connection point between the two ground planes (required to maintain a common ground voltage potential) should be located under the CS4205. The AC-link digital interface connec-

tion traces should be routed such that the digital ground plane lies underneath these signals (on the internal ground layer). This applies along the entire length of these traces from the AC '97 controller to the CS4205.

Refer to the Application Note *AN18: Layout and Design Rules for Data Converters and Other Mixed Signal Devices* [2] for more information on layout and design rules.

## Schematic & Layout Review Service

**Confirm Optimum  
Schematic & Layout  
Before Building Your Board.**

**For Our Free Review Service  
Call Applications Engineering.**

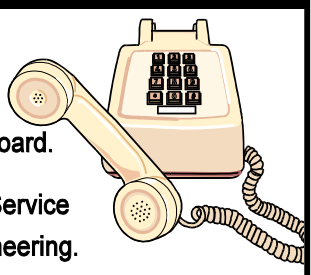

C a l l : ( 5 1 2 ) 4 4 5 - 7 2 2 2

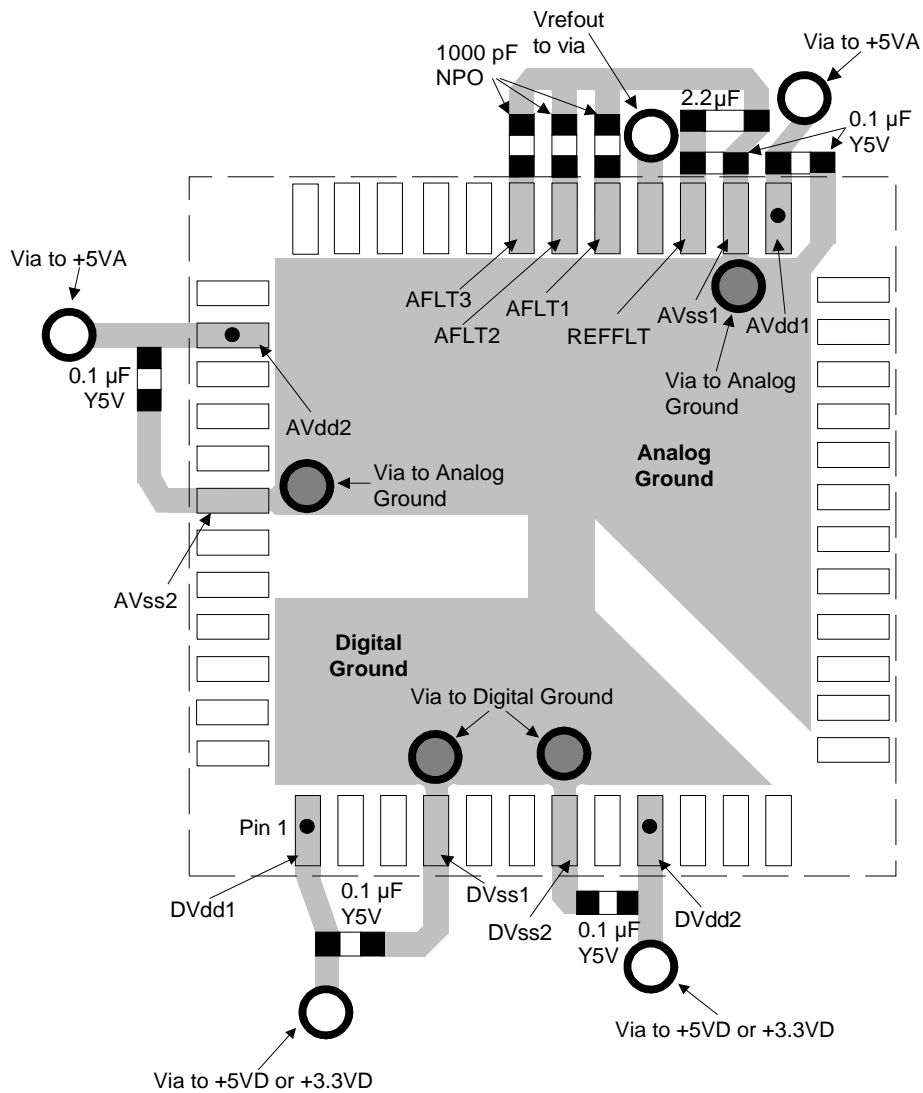

**Figure 33. Conceptual Layout for the CS4205 when in XTAL or OSC Clcking Modes**

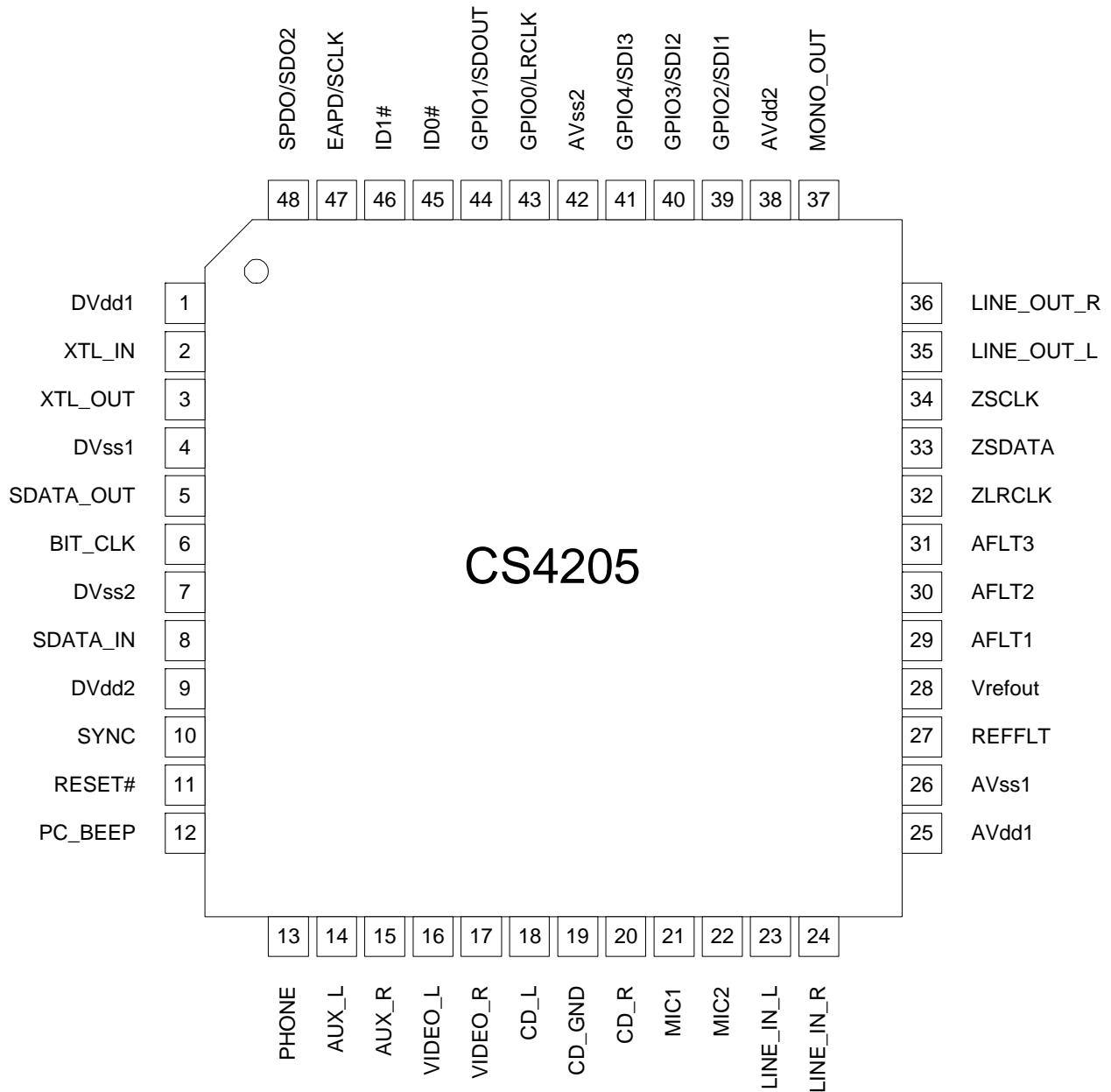
**14. PIN DESCRIPTIONS**

**Figure 34. Pin Locations for the CS4205**

## Audio I/O Pins

### **PC\_BEEP - Analog Mono Source, Input, Pin 12**

The PC\_BEEP input is intended to allow the PC system POST (Power On Self-Test) tones to pass through to the audio subsystem. The PC\_BEEP input has two connections: the first connection is to the analog output mixer, the second connection is directly to the LINE\_OUT stereo outputs. While the RESET# pin is actively being asserted to the CS4205, the PC\_BEEP bypass path to the LINE\_OUT outputs is enabled. While the CS4205 is in normal operation mode with RESET# de-asserted, PC\_BEEP is a monophonic source to the analog output mixer. The maximum allowable input is  $1 V_{RMS}$  (sinusoidal). This input is internally biased at the Vrefout voltage reference and requires AC-coupling to external circuitry. If this input is not used, it should be connected to the Vrefout pin or AC-coupled to analog ground.

### **PHONE - Analog Mono Source, Input, Pin 13**

This analog input is a monophonic source to the output mixer. It is intended to be used as a modem subsystem input to the audio subsystem. The maximum allowable input is  $1 V_{RMS}$  (sinusoidal). This input is internally biased at the Vrefout voltage reference and requires AC-coupling to external circuitry. If this input is not used, it should be connected to the Vrefout pin or AC-coupled to analog ground.

### **MIC1 - Analog Mono Source, Input, Pin 21**

This analog input is a monophonic source to the analog output mixer. It is intended to be used as a desktop microphone connection to the audio subsystem. The CS4205 internal mixer's microphone input is MUX selectable with either MIC1 or MIC2 as the input. The maximum allowable input is  $1 V_{RMS}$  (sinusoidal). This input is internally biased at the Vrefout voltage reference and requires AC-coupling to external circuitry. If this input is not used, it should be connected to the Vrefout pin or AC-coupled to analog ground.

### **MIC2 - Analog Mono Source, Input, Pin 22**

This analog input is a monophonic source to the analog output mixer. It is intended to be used as an alternate microphone connection to the audio subsystem. The CS4205 internal mixer's microphone input is MUX selectable with either MIC1 or MIC2 as the input. The maximum allowable input is  $1 V_{RMS}$  (sinusoidal). This input is internally biased at the Vrefout voltage reference and requires AC-coupling to external circuitry. If this input is not used, it should be connected to the Vrefout pin or AC-coupled to analog ground.

### **LINE\_IN\_L, LINE\_IN\_R - Analog Line Source, Inputs, Pins 23 and 24**

These inputs form a stereo input pair to the CS4205. The maximum allowable input is  $1 V_{RMS}$  (sinusoidal). These inputs are internally biased at the Vrefout voltage reference and require AC-coupling to external circuitry. If these inputs are not used, they should both be connected to the Vrefout pin or AC-coupled to analog ground.

### **CD\_L, CD\_R - Analog CD Source, Inputs, Pins 18 and 20**

These inputs form a stereo input pair to the CS4205. It is intended to be used for the Red Book CD audio connection to the audio subsystem. The maximum allowable input is  $1 V_{RMS}$  (sinusoidal). These inputs are internally biased at the Vrefout voltage reference and require AC-coupling to external circuitry. If these inputs are not used, they should both be connected to the Vrefout pin or AC-coupled to analog ground.

### **CD\_GND - Analog CD Common Source, Input, Pin 19**

This analog input is used to remove common mode noise from Red Book CD audio signals. The impedance on the input signal path should be one half the impedance on the CD\_L and CD\_R input paths. This pin requires AC-coupling to external circuitry. If this input is not used, it should be connected to the Vrefout pin or AC-coupled to analog ground.

**VIDEO\_L, VIDEO\_R - Analog Video Audio Source, Inputs, Pins 16 and 17**

These inputs form a stereo input pair to the CS4205. It is intended to be used for the audio signal output of a video device. The maximum allowable input is  $1 V_{RMS}$  (sinusoidal). These inputs are internally biased at the Vrefout voltage reference and require AC-coupling to external circuitry. If these inputs are not used, they should both be connected to the Vrefout pin or AC-coupled to analog ground.

**AUX\_L, AUX\_R - Analog Auxiliary Source, Inputs, Pins 14 and 15**

These inputs form a stereo input pair to the CS4205. The maximum allowable input is  $1 V_{RMS}$  (sinusoidal). These inputs are internally biased at the Vrefout voltage reference and require AC-coupling to external circuitry. If these inputs are not used, they should both be connected to the Vrefout pin or AC-coupled to analog ground.

**LINE\_OUT\_L, LINE\_OUT\_R - Analog Line-Level, Outputs, Pins 35 and 36**

These signals are analog outputs from the stereo output mixer. The full-scale output voltage for each output is nominally  $1 V_{RMS}$  (sinusoidal). These outputs are internally biased at the Vrefout voltage reference and require either AC-coupling to external circuitry or DC-coupling to a buffer op-amp biased at the Vrefout voltage. These pins need a 680-1000 pF NPO capacitor attached to analog ground.

**MONO\_OUT - Analog Mono Line-Level, Output, Pin 37**

This signal is an analog output from the stereo-to-mono mixer. The full-scale output voltage for this output is nominally  $1 V_{RMS}$  (sinusoidal). This output is internally biased at the Vrefout voltage reference and requires either AC-coupling to external circuitry or DC-coupling to a buffer op-amp biased at the Vrefout voltage. This pin needs a 680-1000 pF NPO capacitor attached to analog ground.

*Analog Reference, Filter, and Configuration Pins***REFFLT - Internal Reference Voltage, Input, Pin 27**

This signal is the voltage reference used internal to the CS4205. A  $0.1 \mu\text{F}$  and a  $2.2 \mu\text{F}$  ceramic capacitor with short, wide traces must be connected to this pin. No other connections should be made to this pin. Do not use an electrolytic  $2.2 \mu\text{F}$  capacitor, use a type Z5U or Y5V ceramic capacitor.

**Vrefout - Voltage Reference, Output, Pin 28**

All analog inputs and outputs are centered around Vrefout, nominally 2.4 Volts. This pin may be used to bias external amplifiers. It can also drive up to 5 mA of DC which can be used for microphone bias.



**AFLT1 - Left ADC Channel Antialiasing Filter, Input, Pin 29**

This pin needs a 1000 pF NPO capacitor connected to analog ground.

**AFLT2 - Right ADC Channel Antialiasing Filter, Input, Pin 30**

This pin needs a 1000 pF NPO capacitor connected to analog ground.

**AFLT3 - Mic ADC Channel Antialiasing Filter, Input, Pin 31**

This pin needs a 1000 pF NPO capacitor connected to analog ground.

AC-Link Pins**RESET# - AC '97 Chip Reset, Input, Pin 11**

This active low signal is the asynchronous Cold Reset input to the CS4205. The CS4205 must be reset before it can enter normal operating mode.

**SYNC - AC-Link Serial Port Sync Pulse, Input, Pin 10**

SYNC is the serial port timing signal for the AC-link. Its period is the reciprocal of the maximum sample rate, 48 kHz. The signal is generated by the controller and is synchronous to BIT\_CLK. SYNC is an asynchronous input when the CS4205 is configured as a primary codec and is in a PR4 powerdown state. A series terminating resistor of 47  $\Omega$  should be connected on this signal close to the controller.

**BIT\_CLK - AC-Link Serial Port Master Clock, Input/Output, Pin 6**

This input/output signal controls the master clock timing for the AC-link. In primary mode, this signal is a 12.288 MHz output clock derived from either a 24.576 MHz crystal or from the internal PLL based on the XTL\_IN input clock. When the CS4205 is in secondary mode, this signal is an input which controls the AC-link serial interface and generates all internal clocking including the AC-link serial interface timing and the analog sampling clocks. A series terminating resistor of 47  $\Omega$  should be connected on this signal close to the CS4205 in primary mode or close to the BIT\_CLK source in secondary mode.

**SDATA\_OUT - AC-Link Serial Data Input Stream to AC '97, Input, Pin 5**

This input signal receives the control information and digital audio output streams. The data is clocked into the CS4205 on the falling edge of BIT\_CLK. A series terminating resistor of 47  $\Omega$  should be connected on this signal close to the controller.

**SDATA\_IN - AC-Link Serial Data Output Stream from AC '97, Output, Pin 8**

This output signal transmits the status information and digital audio input streams from the ADCs. The data is clocked out of the CS4205 on the rising edge of BIT\_CLK. A series terminating resistor of 47  $\Omega$  should be connected on this signal close to the CS4205.

### Clock and Configuration Pins

#### **XTL\_IN - Crystal Input / Clock Input, Pin 2**

This pin requires either a 24.576 MHz crystal, with the other pin attached to XTL\_OUT, or an external CMOS clock. XTL\_IN must have a crystal or clock source attached for proper operation except when operating in secondary codec mode. The crystal frequency must be 24.576 MHz and designed for fundamental mode, parallel resonance operation. If an external CMOS clock is used to drive this pin, it must run at one of these acceptable frequencies: 14.31818, 24.576, 27, or 48 MHz. When configured as a secondary codec, all timing is derived from the BIT\_CLK input signal and this pin should be left floating. See Section 11, *Clocking*, for additional details.

#### **XTL\_OUT - Crystal Output / PLL Loop Filter, Pin 3**

This pin is used for a crystal placed between this pin and XTL\_IN. If an external 24.576 MHz clock is used on XTL\_IN, this pin must be left floating with no traces or components connected to it. If one of the other acceptable clocks is used on XTL\_IN, this pin must be connected to a loop filter circuit. See Section 11, *Clocking*, for additional details.

#### **ID1#, ID0# - Codec ID, Inputs, Pins 45 and 46**

These pins select the Codec ID for the CS4205, as well as determine the rate of the incoming clock in PLL mode. They are only sampled after the rising edge of RESET#. These pins are internally pulled up to the digital supply voltage and should be left floating for logic '0' or tied to digital ground for logic '1'.

### Misc. Digital Interface Pins

#### **SPDO/SDO2 - Sony/Philips Digital Interface / Serial Data Output 2, Output, Pin 48**

This pin generates the S/PDIF digital output from the CS4205 when the SPEN bit in the *S/PDIF Control Register (Index 68h)* is 'set'. This output may be used to directly drive a resistive divider and coupling transformer to an RCA-type connector for use with consumer audio equipment. This pin also provides the serial data for the second serial data port when the SDO2 bit in the *Serial Port Control Register (Index 6Ah)* is 'set'. These two functions are mutually exclusive. When neither function is being used this output is driven to a logic '0'.

#### **EAPD/SCLK - External Amplifier Powerdown / Serial Clock, Output, Pin 47**

This pin is used to control the powerdown state of an audio amplifier external to the CS4205. The output is controlled by the EAPD bit in the Powerdown Ctrl/Stat Register (Index 26h). It is driven as a normal CMOS output and defaults low ('0') upon power-up. This pin also provides the serial clock for all serial data ports when the SDSC bit in the *Serial Port Control Register (Index 6Ah)* is 'set'.

#### **GPIO0/LRCLK - General Purpose I/O / Left-Right Clock, Input/Output, Pin 43**

This pin is a general purpose I/O pin that can be used to interface with various external circuitry. When configured as an input, it functions as a Schmitt triggered input with 350 mV hysteresis at 5 V and 220 mV hysteresis at 3.3 V. When configured as an output, it can function as a normal CMOS output (4 mA drive) or as an open drain output. This pin also provides the L/R clock for all serial data ports when the SDEN bit in the *Serial Port Control Register (Index 6Ah)* is 'set'. This pin powers up in the high impedance state for backward compatibility.

#### **GPIO1/SDOUT - General Purpose I/O / Serial Data Output, Input/Output, Pin 44**

This pin is a general purpose I/O pin that can be used to interface with various external circuitry. When configured as an input, it functions as a Schmitt triggered input with 350 mV hysteresis at 5 V and 220 mV hysteresis at 3.3 V. When configured as an output, it can function as a normal CMOS output (4 mA drive) or as an open drain output. This pin also provides the serial data for the first serial data port when the SDEN bit in the *Serial Port Control Register (Index 6Ah)* is 'set'. This pin powers up in the high impedance state for backward compatibility.

#### **GPIO2/SDI1 - General Purpose I/O / Serial Data Input 1, Input/Output, Pin 39**

This pin is a general purpose I/O pin that can be used to interface with various external circuitry. When configured as an input, it functions as a Schmitt triggered input with 350 mV hysteresis at 5 V and 220 mV hysteresis at 3.3 V. When configured as an output, it can function as a normal CMOS output (4 mA drive) or as an open drain output. This pin also receives the serial data for the first serial input port when the SDI1 bit in the *Serial Port Control Register (Index 6Ah)* is 'set'. This pin powers up in the high impedance state for backward compatibility.

#### **GPIO3/SDI2 - General Purpose I/O / Serial Data Input 2, Input/Output, Pin 40**

This pin is a general purpose I/O pin that can be used to interface with various external circuitry. When configured as an input, it functions as a Schmitt triggered input with 350 mV hysteresis at 5 V and 220 mV hysteresis at 3.3 V. When configured as an output, it can function as a normal CMOS output (4 mA drive) or as an open drain output. This pin also receives the serial data for the second serial input port when the SDI2 bit in the *Serial Port Control Register (Index 6Ah)* is 'set'. This pin powers up in the high impedance state for backward compatibility.

#### **GPIO4/SDI3 - General Purpose I/O / Serial Data Input 3, Input/Output, Pin 41**

This pin is a general purpose I/O pin that can be used to interface with various external circuitry. When configured as an input, it functions as a Schmitt triggered input with 350 mV hysteresis at 5 V and 220 mV hysteresis at 3.3 V. When configured as an output, it can function as a normal CMOS output (4 mA drive) or as an open drain output. This pin also receives the serial data for the third serial input port when the SDI3 bit in the *Serial Port Control Register (Index 6Ah)* is 'set'. This pin powers up in the high impedance state for backward compatibility.

#### **ZLRCLK - ZV Port Left-Right Clock, Input, Pin 32**

This pin receives the Left/Right clock for the Zoomed Video Port. The L/R clock determines which channel is currently being inputted on the ZSDATA pin. The signal must conform to the ZV Port Specification.

#### **ZSDATA - ZV Port Serial Data, Input, Pin 33**

This pin receives two's complement MSB-first serial audio data for the Zoomed Video Port. The data is clocked into the CS4205 by the ZSCLK, and the channel is determined by ZLRCLK. The signal must conform to the ZV Port Specification.

#### **ZSCLK - ZV Port Serial Clock, Input, Pin 34**

This pin receives the serial clock for the Zoomed Video Port. The serial clock is used to clock data on the ZSDATA pin into the CS4205. The signal must conform to the ZV Port Specification.

### Power Supply Pins

#### **DVdd1, DVss1 - Digital Supply Voltage 1 / Digital Ground 1, Pins 1 and 4**

These pins provide the supply voltage and ground for the clocking section of the CS4205. In XTAL or OSC clocking modes DVdd1 should be tied to +5 VD or to +3.3 VD, with DVss1 tied to DGND. In PLL clocking mode, DVdd1 must be tied to +5 VA and DVss1 must be tied to AGND. If connecting these pins to +5 VD or to +3.3 VD and DGND, the CS4205 and controller AC-link should share a common digital supply.

**DVdd2, DVss2 - Digital Supply Voltage 2 / Digital Ground 2, Pins 9 and 7**

These pins provide the digital supply voltage and digital ground for the AC-link section of the CS4205. In all clocking modes DVdd2 should be tied to +5 VD or to +3.3 VD, with DVss2 tied to DGND. The CS4205 and controller AC-link should share a common digital supply. DVss2 should be isolated from analog ground currents.

**AVdd1, AVss1 - Analog Supply Voltage 1 / Analog Ground 1, Pins 25 and 26**

These pins provide the analog supply voltage and analog ground for the analog and mixed signal sections of the CS4205. AVdd1 must be tied to the +5 VA power supply, with AVss1 connected to AGND. It is strongly recommended the +5 VA power supply be generated from a voltage regulator to ensure proper supply currents and noise immunity from the rest of the system. AVss2 should be isolated from digital ground currents

**AVdd2, AVss2 - Analog Supply Voltage 2 / Analog Ground 2, Pins 38 and 42**

The AVdd2 and AVss2 pins are not used on the CS4205 and may be left floating or tied to +5 VA and AGND for backwards compatibility

## 15. PARAMETER AND TERM DEFINITIONS

### AC '97 Specification

Refers to the *Audio Codec '97 Component Specification Ver 2.1* published by the Intel® Corporation [6].

### AC '97 Controller or Controller

Refers to the control chip which interfaces to the audio codec AC-link. This has been also called *DC '97* for Digital Controller '97 [6].

### AC '97 Registers or Codec Registers

Refers to the 64-field register map defined in the AC '97 Specification.

### ADC

Refers to a single Analog-to-Digital converter in the CS4205. "ADCs" refers to the stereo pair of Analog-to-Digital converters. The CS4205 ADCs have 18-bit resolution.

### Codec

Refers to the chip containing the ADCs, DACs, and analog mixer. In this data sheet, the codec is the CS4205.

### DAC

Refers to a single Digital-to-Analog converter in the CS4205. "DACs" refers to the stereo pair of Digital-to-Analog converters. The CS4205 DACs have 20-bit resolution.

### dB FS A

dB FS is defined as dB relative to full-scale. The "A" indicates an A weighting filter was used.

### Differential Nonlinearity

The worst case deviation from the ideal code width. Units in LSB.

### Dynamic Range (DR)

DR is the ratio of the RMS full-scale signal level divided by the RMS sum of the noise floor, in the presence of a signal, available at any instant in time (no change in gain settings between measurements). Measured over a 20 Hz to 20 kHz bandwidth with units in dB FS A.

### FFT

Fast Fourier Transform.

### Frequency Response (FR)

FR is the deviation in signal level verses frequency. The 0 dB reference point is 1 kHz. The amplitude corner,  $A_c$ , lists the maximum deviation in amplitude above and below the 1 kHz reference point. The listed minimum and maximum frequencies are guaranteed to be within the  $A_c$  from minimum frequency to maximum frequency inclusive.

### Fs

Sampling Frequency.

### Interchannel Gain Mismatch

For the ADCs, the difference in input voltage to get an equal code on both channels. For the DACs, the difference in output voltages for each channel when both channels are fed the same code. Units are in dB.

## Interchannel Isolation

The amount of 1 kHz signal present on the output of the grounded AC-coupled line input channel with 1 kHz, 0 dB, signal present on the other line input channel. Units are in dB.

## Line-level

Refers to a consumer equipment compatible, voltage driven interface. The term implies a low driver impedance and a minimum 10 k $\Omega$  load impedance.

## PATHS

A-D: Analog in, through the ADCs, onto the serial link.

D-A: Serial interface inputs through the DACs to the analog output.

A-A: Analog in to Analog out (analog mixer).

## PC 99

Refers to the *PC 99 System Design Guide* published by the Microsoft® Corporation [7].

## PC 2001

Refers to the *PC 2001 System Design Guide* published by the Microsoft® Corporation [8].

## PLL

Phase Lock Loop. Circuitry for generating a desired clock from an external clock source.

## Resolution

The number of bits in the output words to the DACs, and in the input words to the ADCs.

## Signal to Noise Ratio (SNR)

SNR, similar to DR, is the ratio of an arbitrary sinusoidal input signal to the RMS sum of the noise floor, in the presence of a signal. It is measured over a 20 Hz to 20 kHz bandwidth with units in dB.

## S/PDIF

Sony/Phillips Digital Interface. This interface was established as a means of digitally interconnecting consumer audio equipment. The documentation for S/PDIF has been superseded by the IEC-958 consumer digital interface document.

## SRC

Sample Rate Converter. Converts data derived at one sample rate to a differing sample rate. The CS4205 operates at a fixed sample frequency of 48 kHz. The internal sample rate converters are used to convert digital audio streams playing back at other frequencies to 48 kHz.

## Total Harmonic Distortion plus Noise (THD+N)

THD+N is the ratio of the RMS sum of all non-fundamental frequency components, divided by the RMS full-scale signal level. It is tested using a -3 dB FS input signal and is measured over a 20 Hz to 20 kHz bandwidth with units in dB FS.

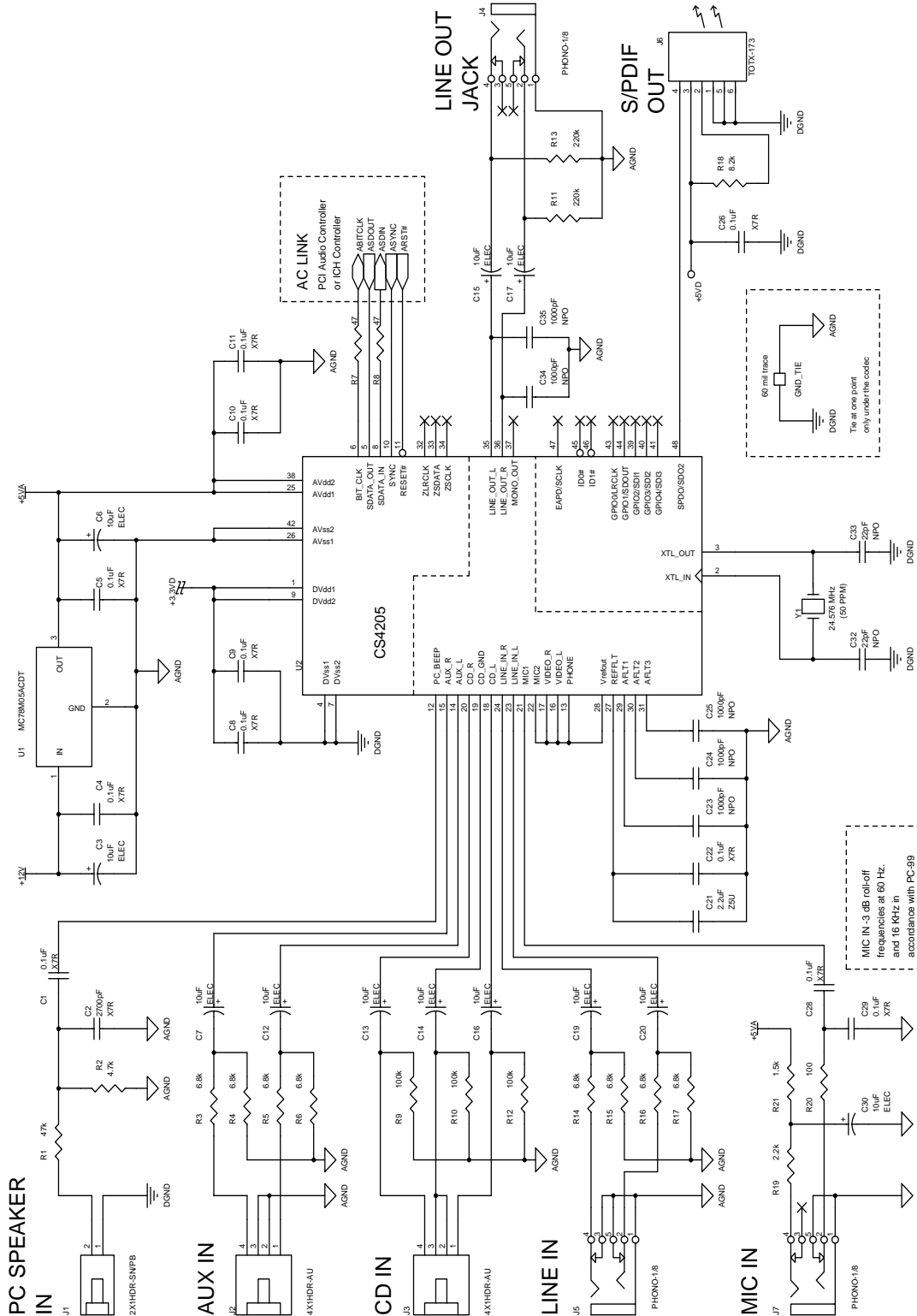
**16. REFERENCE DESIGN**

**Figure 35. CS4205 Reference Design**

---

## 17. REFERENCES

- 1) Cirrus Logic, Audio Quality Measurement Specification, Version 1.0, 1997  
*<http://www.cirrus.com/products/papers/meas/meas.html>*
- 2) Cirrus Logic, AN18: Layout and Design Rules for Data Converters and Other Mixed Signal Devices, Version 6.0, February 1998
- 3) Cirrus Logic, AN22: Overview of Digital Audio Interface Data Structures, Version 2.0, February 1998
- 4) Cirrus Logic, AN134: AES and S/PDIF Recommended Transformers, Version 2, April 1999
- 5) Cirrus Logic, AN165: CS4297A/CS4299 EMI Reduction Techniques, Version 1.0, September 1999
- 6) Intel®, Audio Codec '97 Component Specification, Revision 2.1, May 1998  
*<http://developer.intel.com/ial/scalableplatforms/audio/index.htm>*
- 7) Microsoft®, PC 99 System Design Guide, Version 1.0, July 1999  
*<http://www.microsoft.com/hwdev/desguid/>*
- 8) Microsoft®, PC 2001 System Design Guide, Version 1.0, November 2000  
*<http://www.pcdesguide.org/pc2001/default.htm>*
- 9) Intel® 82801AA (ICH) and 82801AB (ICH0) I/O Controller Hub, June 1999  
*<http://developer.intel.com/design/chipsets/datashts/290655.htm>*
- 10) Intel® 82801BA (ICH2) I/O Controller Hub, October 2000  
*<http://developer.intel.com/design/chipsets/datashts/290687.htm>*
- 11) Intel® 82801CAM (ICH3-M) I/O Controller Hub, July 2001  
*<http://developer.intel.com/design/chipsets/datashts/290716.htm>*

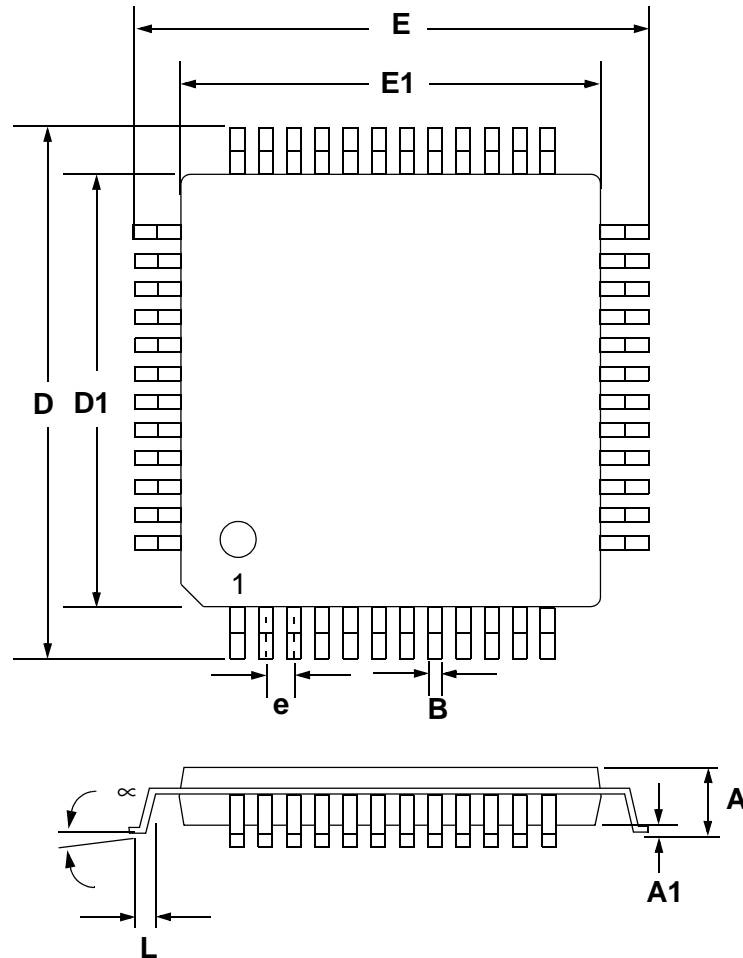

**18. PACKAGE DIMENSIONS**
**48L LQFP PACKAGE DRAWING**

DIM	INCHES			MILLIMETERS		
	MIN	NOM	MAX	MIN	NOM	MAX
A	---	0.055	0.063	---	1.40	1.60
A1	0.002	0.004	0.006	0.05	0.10	0.15
B	0.007	0.009	0.011	0.17	0.22	0.27
D	0.343	0.354	0.366	8.70	9.0 BSC	9.30
D1	0.272	0.28	0.280	6.90	7.0 BSC	7.10
E	0.343	0.354	0.366	8.70	9.0 BSC	9.30
E1	0.272	0.28	0.280	6.90	7.0 BSC	7.10
e*	0.016	0.020	0.024	0.40	0.50 BSC	0.60
L	0.018	0.24	0.030	0.45	0.60	0.75
∞	0.000°	4°	7.000°	0.00°	4°	7.00°

\* Nominal pin pitch is 0.50 mm

Controlling dimension is mm.

JEDEC Designation: MS022